



AGENDA

BOARD OF DIRECTORS REGULAR MEETING

Wednesday, April 26, 2023 - 2pm

West Center Auditorium / Zoom

*Code of Conduct

Directors: Marge Garneau (President), Carol Crothers (Vice President), Bart Hillyer (Secretary), Jim Carden (Treasurer), Barbara Blake (Assistant Secretary), Laurel Dean (Assistant Treasurer), Nancy Austin, Kathi Bachelor, Ted Boyett, Beth Dingman, Steve Gilbert, Bev Lawless, Scott Somers (non-voting)

AGENDA TOPIC

- 1. Call to Order / Roll Call – Establish Quorum**
- 2. Amend/Adopt Agenda**
- 3. President’s Report**
- 4. CEO Report**
- 5. Member Comments** – regarding Consent Agenda and/or Non-Agenda Items – Speakers are asked to provide their name and GVR member number. Please limit comments to two (2) minutes.
- 6. Presentations**
 - A. Quarterly Financial and Personnel Costs (Webster)
- 7. Committee Reports**
 - A. Audit (Austin)
 - B. Board Affairs (Crothers)
 - C. Fiscal Affairs (Carden)
 - D. Investments (Lawless)
 - E. Nominations & Elections (Dingman)
 - F. Planning & Evaluation (Bachelor)
- 8. Consent Agenda** – Consent Agenda items are routine items of business that are collectively presented for approval through a single motion. A Board member may request that an item be pulled from the Consent Agenda and placed under Action Items for separate discussion and action.
 - A. Minutes:
 - 1) BOD Regular Meeting Minutes: March 22, 2023
 - 2) BOD Special Meeting Minutes: March 29, 2023
 - 3) BOD Special Meeting Minutes: April 5, 2023
- 9. Action Items**
 - A. Approve Annual Meeting Calendar (President)
 - B. 2022 Surplus Transfer (Webster)
 - C. Discuss and Award Contract for Security Cameras (Somers)
- 10. Member Comments** - Please limit comments to two (2) minutes.
- 11. Adjournment**

Green Valley Recreation, Inc							
Summary of Revenue & Expenditures - Budget to Actual							
For Fiscal Year Ending Dec 31, 2023							
Quarterly Board Report January - March 2023							
	2022 Annual Budget	January - March 2023			Prior Year		
		YTD Budget	Actual 1Q YTD	% of Variance	FY 2022 1Q YTD	Var. from Prior Year %	\$
Revenue:							
Member Dues	\$ 7,055,850	\$ 1,763,963	\$ 1,764,889	0.1%	\$ 1,745,784	1.1%	\$ 19,105
LC,Trans., Crd Fees.	756,945	272,835	237,744	(12.9%)	280,826	(15.3%)	(43,082)
Capital Revenue	3,328,040	943,677	602,264	(36.2%)	957,649	(37.1%)	(355,385)
Recreation	559,307	310,581	202,951	(34.7%)	197,796	2.6%	5,156
Investment Income	286,884	80,617	133,001	65.0%	97,129	36.9%	35,872
Communication	34,195	6,675	11,698	75.2%	8,240	42.0%	3,459
Other Revenue	89,979	49,728	48,291	(2.9%)	55,849	(13.5%)	(7,558)
Total Revenue	12,111,200	3,428,076	3,000,840	(12.5%)	\$ 3,343,272	(10.2%)	\$ (342,433)
Expenditures:							
Facilities & Equipment NO DEPRECIATI	\$ 2,034,270	\$ 527,354	\$ 570,454	(4.7%)	\$ 465,501	(22.5%)	\$ (104,954)
Personnel	5,723,800	1,389,100	1,322,469	4.8%	1,281,283	(3.2%)	\$ (41,186)
Program	517,295	302,555	214,109	29.2%	251,128	14.7%	\$ 37,018
Communications	234,905	59,726	54,288	9.1%	47,558	(14.2%)	\$ (6,730)
Operations	601,031	83,774	117,387	(40.1%)	72,783	(61.3%)	\$ (44,604)
Corporate Expenses	675,904	192,245	208,925	(8.7%)	147,109	(42.0%)	\$ (61,816)
Total Expenditures	9,787,204	2,554,754	2,487,633	2.4%	2,265,361	(9.8%)	\$ (222,272)
Excess Revenues Over Exp.	\$ 2,323,996	\$ 873,322	\$ 513,207		\$ 1,077,911		\$ (564,704)
Transfers and Adjustments:							
Non Reserve Capital Projects	(308,000)	(77,000)	(9,320)				
Remove Income From Reserves	(247,772)	(61,943)	(71,050)				
Reserve Funding Initiatives	(670,625)	(167,656)	(95,418)				
Reserve Funding MRR & MRR-B	(1,469,339)	(1,469,339)	(1,469,339)				
MRR Expenses paid by Reserve	285,239	71,310	-				
Deduct Reserve Investment Exp.	86,501	21,625	19,032				
Modified Accrual Basis Surplus	-	(809,681)	(1,112,888)				

This report is not a GAAP compliant statement. Non cash adjustments such as Depreciation of Fixed Assets have been removed to establish a Modified Accrual report. The purpose of this report is to give a high level summary of GVRs performance for comparison to the Zero Surplus Budget goal for the fiscal year.

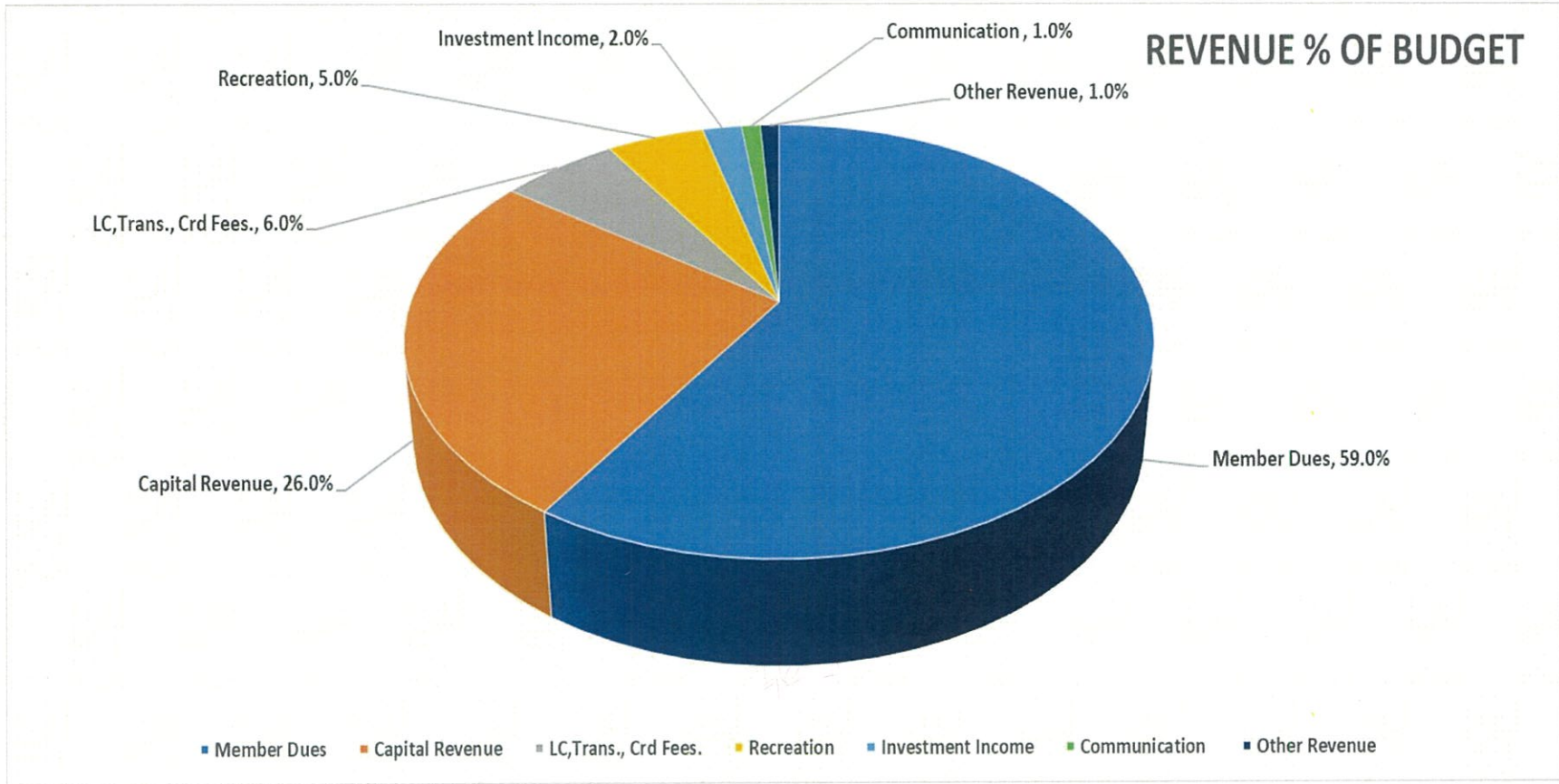

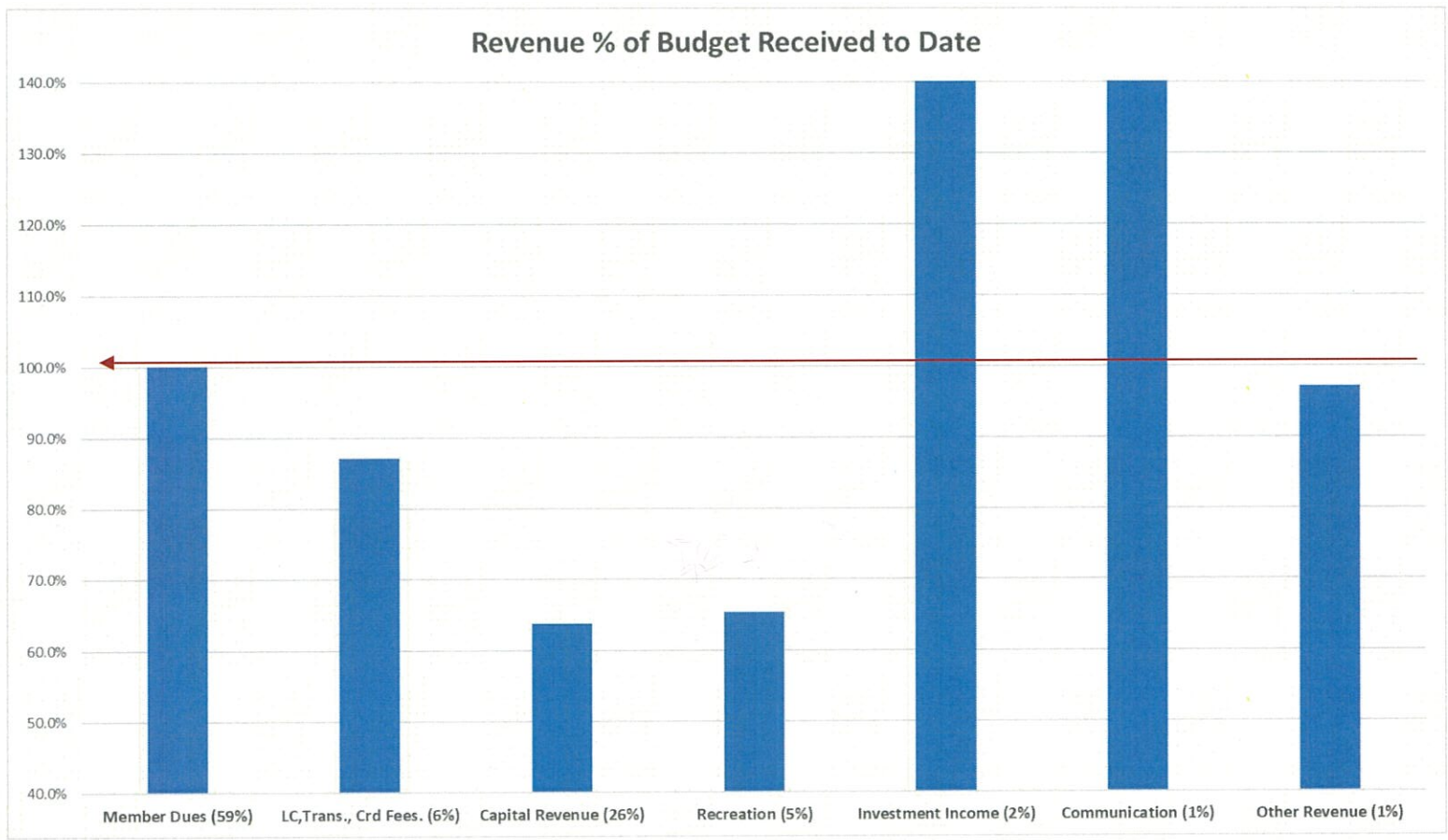

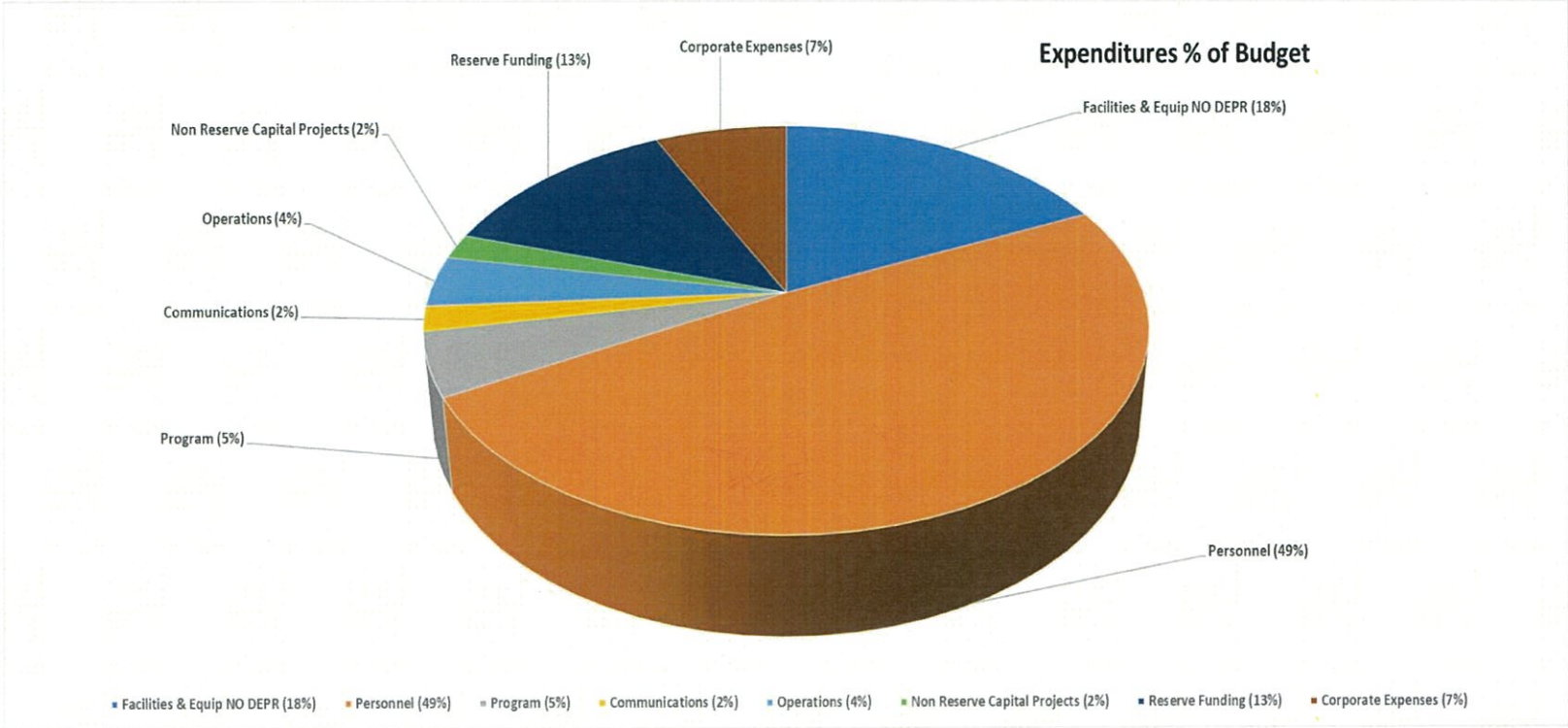

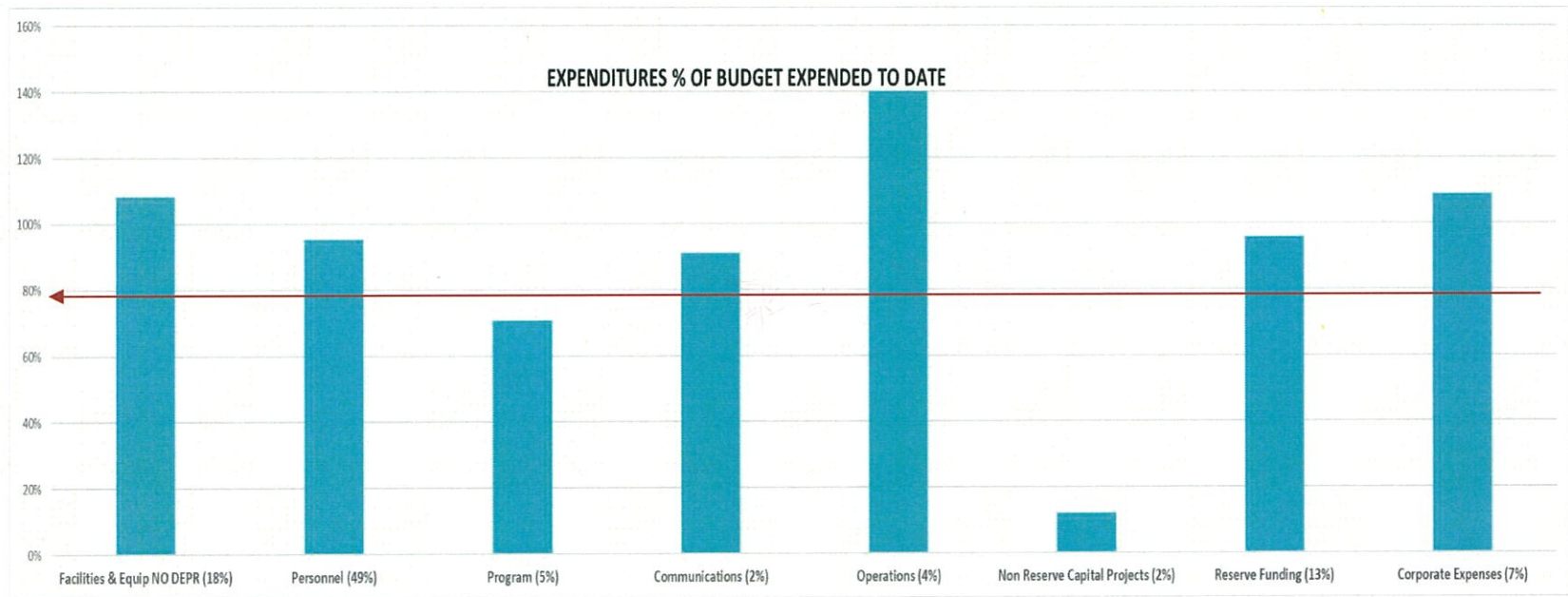



Green Valley Recreation, Inc
Statement of Financial Position
March 31, 2023

	Current March 31, 2023	Prior Year March 31, 2022	Increase (Decrease)	
Assets				
Total Operating Cash	5,994,008	6,080,186	(86,179)	(1%)
Accounts Receivable (net)	568,064	509,186	58,878	12%
Designated Investments	12,032,262	13,092,238	(1,059,976)	(8%)
Prepaid Expenses & Inventory	111,933	135,303	(23,370)	(17%)
Total Current Assets	18,706,266	19,816,914	(1,110,648)	(6%)
Fixed Assets				
Net Fixed Assets	19,185,872	18,042,696	1,143,176	6%
Oper. & Finance ROU	111,822	-		
Total Assets	38,003,960	37,859,610	144,350	0%
Liabilities				
Accounts Payables	521,248	512,970	8,279	2%
Deffered Dues & Fees	5,436,771	5,265,508	171,263	3%
Compensation Liability	-	-	-	0%
Short Term Liabilities	260,258	351,812	(91,554)	(26%)
Long Term Liabilities	145,928	-	145,928	0%
Total Liabilities	6,364,205	6,130,289	233,916	4%
Total Net Assets	31,639,755	31,729,320	(89,566)	(0%)
Net Assets				
Board Designated Net Assets	12,032,262	13,092,238	(1,059,976)	(8%)
Unrestricted Net Assets	19,248,340	18,758,980	489,360	3%
Net Change Year-To-Date	359,153	(121,898)	481,051	395%
Total Net Assets	31,639,755	31,729,320	(89,565)	(0.28%)

Green Valley Recreation, Inc.							
Investments Performance							
Quarterly Board Report January - March 2023							
Fund	March 31, 2023	December 31, 2022	RETURN ON INVESTMENT				
			Year To Date		One Year (12 months)		
			Actual	Benchmark *	Actual	Benchmark *	
Maintenance Repair & Replacement (SBH)	\$ 8,355,614	\$ 7,043,208	2.4%	3.4%	-3.9%	-2.7%	
MRR - Part B Pools and Spas (SBH) **	\$ 770,015	\$ 576,963	1.7%	3.6%	2.2%	-6.6%	
Initiatives (SBH)	\$ 2,402,584	\$ 2,531,557	2.1%	2.7%	-2.5%	-1.7%	
Emergency (SBH)	\$ 504,049	\$ 490,701	2.7%	5.6%	-9.3%	-5.9%	
Total Designated Reserves:	\$ 12,032,262	\$ 10,642,430					
Operating Investment Fund Part A Short Term - JP Morgan	\$ 3,643,994	\$ 3,361,830	1.1%	1.5%	2.6%	2.5%	
Operating Investment Fund Part B Long Term - JP Morgan	\$ 1,572,980	\$ 1,600,000	1.9%	1.9%	-3.0%	-2.9%	
Total Invested Operating Cash	\$ 5,216,974	\$ 4,961,830					

* Benchmarks = standards established by the Investments Committee in the Investment Policy Statement to compare the performance of a GVR Fund to a blend of Investment Indexes that match the risk tolerance and investment horizon of each fund. These benchmarks can be found in Subsection 3. GVR Investment Policy Statement in the Appendix of the CPM.



The following Personnel Costs analysis is in response to our CEO request to provide a high level overview of long term and short term growth in Personnel costs with the goal of obtaining an accurate understanding of whether the Personnel costs are reasonable and supported by the level of revenue generated by GVR..

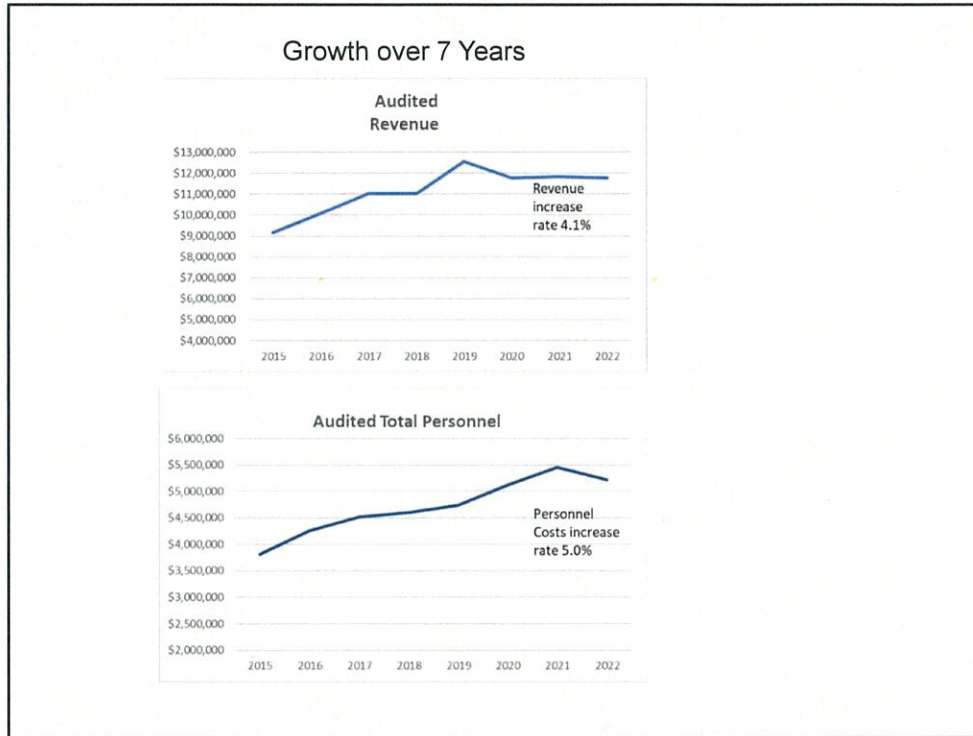

Over the past 7 years, the average annual growth in revenue has been 4.1% compared to a 5.0% annual growth rate in Personnel costs. While the difference seems to be a small number, the Personnel costs growth are 22% more than the growth in Revenue. It is important to note that the past 3 years, the growth in Personnel costs declined to 3.4%. The trend is in the right direction.

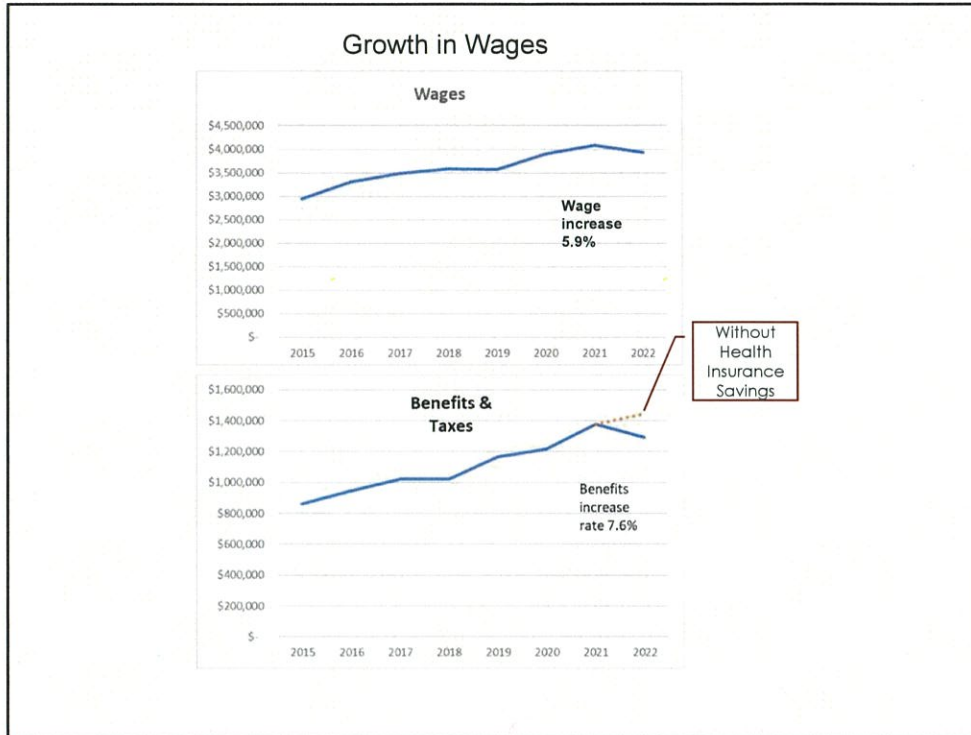

These 7 year trend graphs breaks down the total Personnel costs into Wages versus Taxes and Benefits. You can see that Benefits have outpaced Wages. Also, you can see with the dashed line that GVR was able reduce this trend by changing our health insurance provider and some revisions to our benefits plan.

Growth in expenses

COMPONENT	3 YEARS	5 YEARS	7 YEARS
GROSS REVENUE INCREASE	-6.1%	6.9%	28.8%
INCREASE IN PERSONNEL EXPENSES	10.3%	15.7%	36.8%
INCREASE IN TOTAL EXP.	1.8%	12.0%	29.2%

This slide shows the total increase in Personnel and Total GVR Expenses, not average annual increases. You can see that the rate of growth is diminishing during the past 3 years. With continued work on both the wages and benefits components side of this equation. We believe that the current trend in Personnel Costs are moving in the right direction.

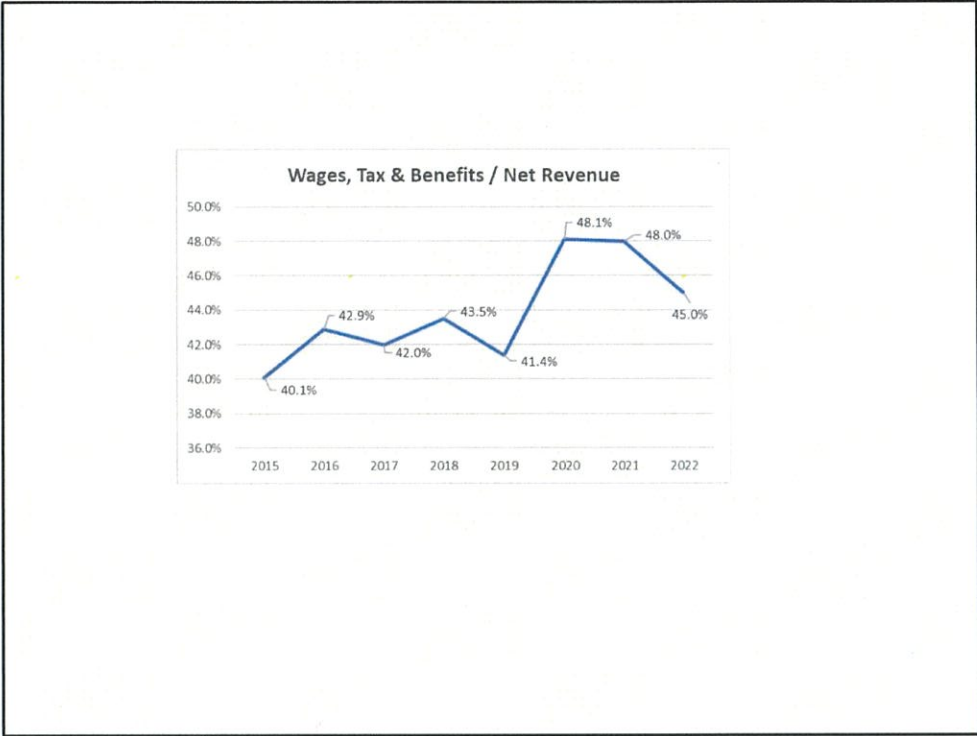

When comparing personnel costs to revenue, it is best to use Net Revenue. Revenue that does not include Investment Income or loss best measures GVR's Operating Income. The Personnel costs compared to this Net Income is trending downward.

	Current Actual	Actual 2022	Actual 2021
Full Time	77	81	82
Part Time	27	29	32
Headcount	104	110	114
% change in Full Time	Decrease 5%	Decrease 1.2%	

The above decrease in full time employees helps us to understand why the benefit costs are decreasing



MINUTES

BOARD OF DIRECTORS MEETING

Wednesday, March 22, 2023 - 2pm

West Center Auditorium / Zoom

*Code of Conduct

Directors: Kathi Bachelor (President), Donna Coon (Vice President), Bart Hillyer (Secretary), Carol Crothers (Treasurer), Laurel Dean (Assistant Secretary), Jim Carden (Assistant Treasurer), Nancy Austin, Barbara Blake, Ted Boyett, Beth Dingman, Steve Gilbert, Bev Lawless, Scott Somers (non-voting)

Staff Present: David Jund (Facilities Director), Nanci Moyo (Administrative Supervisor), David Webster (CFO), Natalie Whitman (COO), Kris Zubicki (Member Services Director)

Visitors: 13 Including support staff

AGENDA TOPIC

1. Call to Order / Roll Call – Establish Quorum

The President being in the chair and the Secretary being present.

President Bachelor called the meeting to order at 2:00pm MST. Secretary Hillyer called the roll; quorum established.

2. Amend/Adopt Agenda

MOTION: Director Boyett moved, Director Blake seconded to adopt the Agenda as amended by moving from the Consent Agenda 7.C.1 and 7.C.3 to be the first actions under the Action Item.

Passed: unanimous

3. Presentation

Freddie Kinnaman recognition for saving a member's life at the Canoa Ranch Pickleball courts by using CPR and the AED machine, along with other members assisting her.

4. President Report

- This is the last Regular meeting of the year before the Annual Meeting on March 29, 2023.
- It has been her pleasure to work with this Board as the President and to have worked closely with CEO Somers. It has been wonderful to work with the CEO and all of the staff at GVR.
- There is time to apply to serve on a Committee. Apply online/email or print a paper copy and send to GVR. Available committees include: Audit Committee, Board Affairs Committee, Fiscal Affairs Committee, Investment Committee, Nominations and Elections Committee, and Planning and Evaluation Committee.

5. CEO Report

- It has been a pleasure working with this Board and President.

- Desert Hills Fitness Center is on schedule. The project will be finished and the equipment will be delivered in May. A ribbon cutting will be scheduled for May, but possibly June.
- Glass Arts Studio space has begun demolition, using GVR staff to keep the cost down. There will be a “ground breaking/wall smashing” event this evening with the Board being invited, along with contractors and others. Great opportunity to celebrate this project moving forward.
- Ceramics Arts Studio design expansion is underway with the architect working on the final designs and development of the construction documents. The construction documents and cost estimates will be brought to the Board when completed to get Board direction.
- Del Sol Clubhouse architectural designs for the upper and lower levels have been submitted to staff. Site work: the parking lot and driveways, and the tile work in the bathrooms all are underway. Once the bathrooms are done the temporary porta potties will be removed. The upper level of Del Sol Clubhouse is being used and GVR has received great feedback from members who are enjoying the Clubhouse.
- Woodshop designs are being drafted by the architect and their mechanical engineer. This was approved as part of the 2023 Club Funding Requests.
- Lapidary potential expansion at West Center will be discussed for program planning.

6. Member Comments – no member comments

7. Consent Agenda

MOTION: Director Boyett moved, Director Blake seconded to approve the Consent Agenda as amended.

Passed: unanimous

A. Minutes

- 1) BOD Regular Meeting Minutes: February 22, 2023
- 2) BOD Special Meeting Minutes: March 8, 2023
- 3) BOD Work Session Meeting Minutes: March 15, 2023

B. Financial Statement

- 1) February Draft Financial Statement

C. Board Business

- 1) Approve Recommended Amendments to CPM Part 7 – **Moved to Action Item**
- 2) CPM Part 6, Section 2 Membership/Guests/Monitoring 6.2.2.K.1-5
- 3) Placement of Board Credo in CPM – **Moved to Action Item**

8. New Business

A. Approve Recommended Amendments to CPM Part 7

MOTION: Director Boyett moved, Director Dingman seconded to approve the recommended amendments to CPM Part 7.

Passed: 9 yes / 3 no (Hillyer, Austin, Dean)

B. Placement of Board Credo in CPM

MOTION: Director Dean moved, Director Hillyer seconded to reject the whole document, except for the first paragraph only to be put in the Corporate Policy Manual.

Passed: 7 yes / no 5 (Bachelor, Boyett, Dingman, Gilbert, Lawless)

MOTION: Director Coon moved, Director Gilbert seconded to approve the Board Affairs Committee decision on the placement of the Board Credo first paragraph in Part 2, Section 1, and renumber the rest of Part 2.

Passed: 11 yes / 1 no (Hillyer)

- C. BAC Recommendation for Board Approval – Italian Club

MOTION: Director Coon moved, Director Crothers seconded to accept the Board Affairs Committee recommendation to approve an application to establish a GVR Italian Club.

Passed: unanimous

- D. 2023 Work Plan Approval

MOTION: Director Crothers moved, Director Coon seconded to approve the 2023 proposed Work Plan.

Passed: unanimous

- E. Authorize Transfer of Expense from Initiatives to Operations and Authorize an Expenditure of Approximately \$79,836 from Initiatives to Pay the Balance Owed on Fitness Equipment for Desert Hills Fitness Center

CFO David Webster said the amount for the final balance is less than stated on the Agenda and Staff Report. The final balance is \$75,403.57.

MOTION: Director Gilbert moved, Director Crothers seconded to authorize the transfer of an expense from Initiatives to Operations and authorize an expenditure of \$75,403.57 from Initiatives to pay the balance owed on fitness equipment for the Desert Hills Fitness Center.

Passed: unanimous

- F. Procurement and Spending Authority Policy

MOTION: Director Crothers moved, Director Boyett seconded to approve the Procurement and Spending Authority Policy and put in the Corporate Policy Manual in Part 5 Fiscal/Accounting, as Section 4.

MOTION TO AMEND: Director Dingman moved, Director Gilbert seconded to move the amount to \$25,000 versus the \$5,000 before a bid or quote is needed.

Failed: 4 yes (Bachelor, Boyett, Dingman, Gilbert) / 7 no (Nancy Austin was not available to vote)

SECOND MOTION TO AMEND: Director Lawless moved, Director Crothers seconded to decrease the amount to \$10,000 from \$25,000.

Passed: 10 yes / 2 no (Bachelor, Dingman)

AMENDED MOTION PASSED: unanimous

Amended Motion: Approve the Procurement and Spending Authority Policy with the amended \$10,000 amount for not requiring a bid and put this policy in the Corporate Policy Manual in Part 5 Fiscal/Accounting, as Section 4.

- G. Major Capital Projects Policy

MOTION: Director Crothers moved, Director Blake seconded to approve the traditional major project approval process is followed until a new policy is defined and approved by the Board. The process is defined in the Board report under Background Justification.

MOTION: Director Crothers moved that the Board request detailed project plans with all contingencies identified for all major projects. Plans will be updated monthly. The Board will commit to addressing any potential delays caused by the Board or its committees.

MOTION TO AMEND: Director Boyett moved, Director Gilbert seconded to amend that both of these motions be sent back to the appropriate committees for recommendations: Board Affairs, Fiscal Affairs, Planning and Evaluation Committees. Then send to staff for direction. Use Director Crothers' recommendation for the committees to work from.

FAILED: 6 yes / 6 no (Austin, Carden, Coon, Crothers, Dean, Hillyer)

MOTION: Director Boyett moved, Director Lawless seconded to table this discussion until we receive more feedback from staff and committees. Bring this back at the June Work Session and Regular Meeting.

Passed: 8 yes / 4 no (Austin, Crothers, Dean, Hillyer)

9. Committee Reports – There were no committee reports due to time. It was suggested to put the Committee Reports at the beginning of the meeting.

- | | |
|----------------------------|----------|
| A. Audit | Austin |
| B. Board Affairs | Coon |
| C. Fiscal Affairs | Crothers |
| D. Investments | Lawless |
| E. Nominations & Elections | Dingman |
| F. Planning & Evaluation | Hillyer |

10. Member Comments – There were no member comments.

Director Coon said this is her last meeting after serving for six years. She enjoyed her last year especially with this Board. She thanked her fellow Directors and members who served on various committees. She has learned so much over all these years and serving on all the committees. She offered that GVR Board be mindful of all the many reasons people move to Green Valley and how GVR is used differently by all these people. Keep making GVR better for the future. She thanked Kathi Bachelor, President, for working well with the CEO and attending all the committee meetings. She thanked the staff, also.

President Bachelor thanked Director Coon for her service and all her knowledge used in her years of service.

11. Adjournment

MOTION: Director Hillyer moved, Director Dean seconded to adjourn the meeting at 3:58pm.

Passed: unanimous



MINUTES

BOARD OF DIRECTORS SPECIAL MEETING

Wednesday, March 29, 2023 – 10:30am

West Center Auditorium / Zoom

*Code of Conduct

Directors: Nancy Austin, Kathi Bachelor, Barbara Blake, Ted Boyett, Jim Carden, Carol Crothers, Laurel Dean, Beth Dingman, Marge Garneau, Steve Gilbert, Bart Hillyer, Bev Lawless, Scott Somers (non-voting)

AGENDA TOPIC

1. Call to Order / Roll Call – Establish Quorum

The President being in the chair and the Secretary being present.

President Bachelor called the meeting to order at 10:23am MST. Secretary Hillyer called the roll; quorum established.

2. Adopt or Amend Agenda

MOTION: Director Bachelor moved, Director Gilbert seconded to amend the Agenda to include Action Items 3.B. Approval of Audit for 2022.

Failed: 6 yes (Bachelor, Blake, Boyett, Dingman, Gilbert, Lawless) / 6 no

3. Action Items

A. Nomination and Election of Board Officers

1) President

a) Nomination

- | | | |
|------------|---|--------------|
| ▪ Bachelor | 5 | will run |
| ▪ Garneau | 6 | will run |
| ▪ Hillyer | 1 | will not run |

b) Election

- | | | |
|------------------|----------|------------------|
| ▪ Bachelor | 5 | |
| ▪ Garneau | 7 | President |

2) Vice-President

a) Nomination

- | | | |
|------------|---|--------------|
| ▪ Bachelor | 1 | will not run |
| ▪ Crothers | 6 | will run |
| ▪ Lawless | 5 | will run |

b) Election

- | | First Vote | Second Vote | Final Vote |
|-------------------|------------|-------------|-------------------------|
| ▪ Crothers | 6 | 6 | 7 Vice-President |
| ▪ Lawless | 5* | 6 | 5 |

*NOTE: The first vote was miscounted due to a blank election card included in Lawless card stack. It was registered as a tie with Crothers 6 and Lawless 6 so it was voted on again.

3) Secretary

a) Nomination

- Bachelor 1 will run
- Dean 1 will not run
- Dingman 4 will run
- Gilbert 2 will run
- Hillyer 4 will run

b) Election

- Bachelor 2
- Dingman 3
- Gilbert 1
- **Hillyer 6 Secretary**

4) Treasurer

a) Nomination

- Bachelor 1 will run
- Blake 1 will not run
- Carden 4 will run
- Dean 1 will not run
- Dingman 1 will not run
- Gilbert 3 will not run

b) Election

- Bachelor 5
- **Carden 7 Treasurer**

5) Assistant Secretary

a) Nomination

- Bachelor 2 will not run
- Blake 7 will run
- Boyett 1 will not run
- Dingman 2 will run

b) Election

- **Blake 8 Assistant Secretary**
- Dingman 4

6) Assistant Treasurer

a) Nomination

- Austin 1 will not run
- Dean 4 will run
- Dingman 2 will not run
- Gilbert 4 will not run
- Lawless 1 will not run

b) Election

- **Dean 10 Assistant Treasurer**

4. Member Comments – 1

GVR Members are encouraged to serve on a GVR Committee. Email Hotline@gvrec.org stating interest in serving on a specific Committee.

5. Adjournment

MOTION: Director Boyett moved, Director Austin seconded to adjourn the meeting at 11:06am MST.

Passed: unanimous

DRAFT



MINUTES

BOARD OF DIRECTORS SPECIAL MEETING

Wednesday, April 5, 2023 - 1pm

West Center Auditorium / Zoom

*Code of Conduct

Directors: Marge Garneau (President), Carol Crothers (Vice President), Bart Hillyer (Secretary), Jim Carden (Treasurer), Barbara Blake (Assistant Secretary), Laurel Dean (Assistant Treasurer), Nancy Austin, Kathi Bachelor, Ted Boyett, Beth Dingman, Steve Gilbert, Bev Lawless, Scott Somers (non-voting)

Visitors: 11 including support staff

AGENDA TOPIC

1. Call to Order / Roll Call – Establish Quorum

The President being in the chair and the Secretary being present.

President Garneau called the meeting to order at 1:01pm MST. Secretary Hillyer called the roll; quorum established.

2. Adopt or Amend Agenda

MOTION: Director Crothers moved, Director Carden seconded to approve the Agenda.

Passed: unanimous

3. Action Items

A. Approval of Committee Chairs

MOTION: Director Blake moved, Director Austin seconded to approve Committee Chairs as appointed by the President: Nancy Austin – Chair of Audit Committee, Carol Crothers – Chair of Board Affairs Committee, Jim Carden – Chair of Fiscal Affairs Committee, Bev Lawless – Chair of Investments Committee, Beth Dingman – Chair of Nominations and Elections Committee, and Kathi Bachelor – Chair of Planning and Evaluation Committee.

Passed: 8 yes / 4 no (Bachelor, Boyett, Gilbert, Lawless)

MOTION TO AMEND: Director Boyett moved, Director Lawless seconded to separate the slate to vote for each Committee Chair.

Failed: 5 yes (Bachelor, Boyett, Dingman, Gilbert, Lawless) / 7 no

B. Acceptance of Audit

David Webster, CFO, asks the Board to formally approve and accept the Audit for 2022.

MOTION: Director Crothers moved, Director Blake seconded to accept the Audit.

Passed: unanimous

4. Member Comments – 1

5. Adjournment

MOTION: Director Dingman moved, Director Crothers seconded to adjourn the meeting at 1:24pm MST.

Passed: unanimous



Green Valley Recreation, Inc.

Board of Directors Meeting

Approval of Tentative Annual Meeting Schedule

Prepared By: Nanci Moyo, Admin. Sup.

Meeting Date: April 26, 2023

Presented By: Marge Garneau, President

Consent Agenda: No

<p>Originating Committee / Department: Board of Directors/Administration</p>
<p>Action Requested: Review and approve the tentative Annual Meeting Schedule.</p>
<p>Strategic Plan Goal: GOAL 5: Provide sound, effective governance and leadership for the corporation</p>
<p>Background Justification: The Corporate Policy Manual (CPM) states in Part 2 Board of Directors, Section 3 Meetings – 2.3.1.D.5 A tentative annual meeting schedule shall be approved by the Board at its first Regular Meeting following the Annual Meeting.</p>
<p>Fiscal Impact: None</p>
<p>Board Options:</p> <ol style="list-style-type: none"> 1) Approve the tentative Annual Meeting Schedule as presented in the Board Calendar and Annual Governance Calendar. 2) Make changes to the tentative Annual Meeting Schedule and approve the changes. 3) Do not take action on the tentative Annual Meeting Schedule.
<p>Staff Recommendation: Option #1</p>
<p>Recommended Motion: Move to approve the tentative Annual Meeting Schedule as presented in the Board Calendar and the Annual Governance Calendar.</p>
<p>Attachments:</p> <ol style="list-style-type: none"> 1) Board Calendar 2) Annual Governance Calendar



BOARD OF DIRECTORS

Thursday, April 20, 2023

2023-2024 MEETING SCHEDULE

(Tentative)

BOD Work Sessions / BOD Meetings

Date	Time	Loc	Type	Agenda Items	Presenter
Wednesday, April 26, 2023	2pm	WC/Zoom	Board of Directors Regular Meeting	Approve Annual Meeting Calendar Quarterly Financial and Personnel Costs Presentation Discuss and Award Contract for Security Cameras 2022 Surplus Transfer	Board President Webster Somers Webster
Wednesday, May 17, 2023	1pm	WC Rm 2	Tentative Board of Directors Executive Session - Closed	Legal Issue Voluntary Deed Request Legal Issue on Potential New Development South of Canoa Ranch	Somers Somers
Wednesday, May 17, 2023	2pm	WC Rm 2/Zoom	Board of Directors Training - Closed	Governance Training - Specifically Committees - Purpose of the Committees	Carrillo
Wednesday, May 24, 2023	2pm	WC/Zoom	Board of Directors Regular Meeting	Approve Committee Work Plans Discuss and Approve Major Capital Projects Process Discuss and Approve Next Steps Ceramics Club Space Discuss and Approve Next Steps Lapidary Club Space	Somers Somers Jund Jund
Wednesday, September 27, 2023	2pm	WC/Zoom	Board of Directors Regular Meeting		
Wednesday, October 18, 2023	2pm	WC/Zoom	Board of Directors Work Session - Tentative	Presentation of Proposed Budget	Webster
Wednesday, October 25, 2023	2pm	WC/Zoom	Board of Directors Regular Meeting	Set Record Date Approve Annual Budget and all Fees Quarterly Financial Presentation Form 990	N&E Chair Webster Webster Webster

BOD Work Sessions / BOD Meetings

Date	Time	Loc	Type	Agenda Items	Presenter
Wednesday, November 15, 2023	2pm	WC/Zoom	Board of Directors Regular Meeting		
Wednesday, January 3, 2024	2pm	WC/Zoom	Board of Directors Executive Session	CEO Evaluation	Board President
Wednesday, January 24, 2024	2pm	WC/Zoom	Board of Directors Regular Meeting		
Wednesday, February 28, 2024	2pm	WC/Zoom	Board of Directors Regular Meeting		
Wednesday, March 20, 2024	2pm	WC/Zoom	Board of Directors Regular Meeting		
Wednesday, March 27, 2024	9am	WC/Zoom	Annual Meeting of the Corporation		
Wednesday, March 27, 2024	10:30am	WC/Zoom	Board of Directors Special Meeting		

ANNUAL REMINDER LIST:

Fees Schedule/Late Fees
 GVR complete GVRF Request for Funding Grant Application for MAP - **every 3 years** Next time: 09012024
 Record Date for Member's Voting - Done at October Reg. Meeting
 Board Annual Dues decision for each fiscal year on or before - Done at October Reg. Mtg (Before Dec. 10 every year) Included in All Fees (above)
 Financial Policies
 Approve Annual Calendar in April Reg. Mtg.
 Review Strategic Plan every April with new Board
 Provide Board the Link to Website in October for Form 990

POTENTIAL AGENDA ITEMS/STAFF ITEMS:

Add Quarterly Reports for April, July, September, January

Annual Board Development & Governance Calendar (March 29, 2023 – March 27, 2024)

Board Year beginning Immediately Following Annual Meeting (End of March) **Dates Before April are 2024**

	Governance Task	January	February	March	April	May	June	July	August	September	October	November	December
Meetings & Key Events	Board Work Session (Tentative)					May 17					Oct 18		
	Board Meetings	Jan 24	Feb 28	Mar 20	Apr 26	May 24				Sep 27	Oct 25	Nov 15	
	Annual Meeting			Mar 27									
	Executive Session	Jan 3				May 17							
Fiduciary	Approve Annual Budget											Nov 15	
	Quarterly Financial Report	Jan 25			Apr 26						Oct 26		
	Audit Review												
	990 Review										Oct 26		
	Budget Planning to Reflect Strategic Priorities												
Board Development	Board Self-Assessment												
	Set Record Date										Oct 25		
	Annual Calendar Review and Approval				Apr 26								
	Election of new board directors			Mar 21									
	Election of Board Officers			Mar 27									
	Committee Applications				Apr 14								
	Committee assignments				Apr 26								
	Strategic Plan Review												
	Annual Work Plan												
	New Board Member Orientation				Apr 5								
Planning	Annual Planning Retreat				Apr 5								
	Online Board Training				Apr 10								
	Board Retreat					May 17							
	Volunteer Recognition Breakfast/Luncheon			Mar 1									
MAP	MAP Application Opening										Oct 16		
	MAP Application Deadline												Dec 15
Chief Executive	Performance Evaluation	Jan 3											



Green Valley Recreation, Inc.
Board of Directors Meeting

2022 Surplus Calculation and Transfer

Prepared By: David Webster, CFO

Meeting Date: April 26, 2023

Presented By: David Webster, CFO

Consent Agenda: No

Originating Committee / Department:

Fiscal Affairs Committee

Action Requested:

Accept the Green Valley Recreation, Incorporated (GVR) 2022 Surplus Calculation and approve a transfer from Operating Cash to Initiatives in the amount of \$428,596.

Strategic Plan Goal:

Goal 4: Cultivate and maintain a sound financial base that generates good value for our members.

Background Justification:

Green Valley Recreation's Surplus Policy is stated in Section 3 – Reserve Policy Part 5.3.2 Part C. entitled **Calculation of Operating Surplus or Deficit**. This policy was updated and approved by the Board of Directors in 2021. The 2022 financial statements have been audited and GVR staff have prepared a surplus calculation for the fiscal year ending December 31, 2022. The amount of the 2022 Surplus is \$428,596.

Fiscal Impact:

The intent of the surplus calculation is to determine if there is a surplus of operating revenue over operating expenses each year that can be transferred to a reserve fund. Approving a transfer of \$428,596 will reduce Operating Cash and increase the Initiatives fund by \$428,596. An estimate of \$400,000 was previously included in the Cash Requirements report for 2023 and the Capital Plan projection for 2023. GVR has sufficient Operating Cash to incur this transfer.

A copy of the updated Capital Plan is included to illustrate that the Initiatives Fund is the appropriate account to deposit the Surplus into. With this \$428,596 transfer, the projected end of year balance of the Initiative Fund is \$446,272.

Board Options:

1. Approve the \$428,596 2022 Surplus transfer out of Operating Cash into the Initiatives Fund.
2. Not approve any transfer for the 2022 Surplus.
3. Approve an alternative to transferring the 2022 Surplus.

Staff Recommendation:

Option #1

Recommended Motion:

Move to accept the Green Valley Recreation, Incorporated (GVR) 2022 Surplus Calculation and approve a transfer from Operating Cash to Initiatives in the amount of \$428,596.

Attachments:

Surplus Calculation

SURPLUS 2022

2022 Actual

Revenue:

Member Dues	6,947,340
Transfer Fees, Tenant, Credit Crd, Life Care Fees	785,602
Capital Revenue	3,099,400
Recreation	401,553
Investment Income	372,078
Communication	43,105
Other Revenue	112,273

Total Revenue**11,761,351****Expenditures:**

Facilities & Equipment with Depreciation	3,367,303
Personnel	5,143,126
Program	463,890
Communications	209,141
Operations	568,449
Corporate Expenses	759,851

Total Expenditures**10,511,760****Excess Revenues Over Exp.****1,249,591****Transfers and Adjustments:**

In Kind Non Cash Revenue	(4,000)
Non Reserve Capital Projects	(192,930)
Remove Income From Reserves	(295,153)
Reserve Funding Initiatives	(623,580)
Reserve Funding MRR & MRR-B	(1,402,519)
MRR Expenses paid by the Reserve	61,951
Remove Reserve Investment Exp.	83,297
Remove Depreciation	1,551,939
Total Adjustments	(820,995)

SURPLUS**428,596**

Analysis of GVR Net Increase in Assets after Reserve Funding

Purpose: To determine if there is sufficient Operating Cash for additional Reserve Funding

	Total Surplus Calculation 12/31/2022	2022 GVR FINANCIAL STATEMENT REFERENCE	2022 GVR AUDIT REPORT REFERENCE	GVR Surplus Formula Ref CPM p 48
	GVR Surplus Formula			
Total Increase in Net Assets	\$ (562,746)	Page 3 December Financial Stmt.	Pg. 4 Statement of Activities	
Reserve Accounts Income: Net Gain / Loss on Investments	\$ 1,812,337	Page 3 and 5 December Financial Stmt.		
Net Increase in Net Assets	\$ 1,249,591	Page 3-4 December Financial Stmt.		a.
Non Cash Contribution: Less Non Cash In Kind Rental Income	\$ (4,000)	Page 3 December Financial Stmt.	Pg. 4 Statement of Activities.	i.
Reserve Income:				
Deduct Net Income of Reserve Accounts and Unrealized Gains on Operating Investments.	\$ (295,153)	Unrealized Gains/Losses on Operating Investments and Reserve Accounts Income deducted to determine funds available from Operations. Investment Expenses Removed. Pages 4-5 December Financial Statement	Designated Reserve portion of Investment Income reported on page 4 and 14 of Audit.	b. c.
\$ (211,856)	\$ -			b. c.
	\$ 83,297			b. c.
Reserves Funding:				
Maintenance Repair & Replacement Reserve Funding for 2022	\$ (1,132,047)	2022 MRR Funding transfer Jan-22 based on Browning Reserve , Page 4	N/A	h.
MRR-B Funding	\$ (270,472)	Page 4	N/A	h.
Initiatives Funding per CPM Formula	\$ (623,580)	2022 Reserve Funding per CPM formula 2022 Initiatives Transfers	N/A	h.
Net Increase after Reserve Funding	\$ (992,364)	Net Increase after deducting 2022 Reserve Funding		n/a
Cash Adjustment for Capital Purchases:				
Add Back Depreciation	\$ 1,551,939	Add Back Non cash Depreciation. (page 4)	Page 6 Statement of Functional Expenses	d.
Deduct Non Reserve Capital Purchases	\$ (192,930)	Page 6 Non Reserve Cash Purchases	N/A	e.
Add Back MRR Expenses paid for out of the MRR Reserve	\$ 61,951	Page 7 MRR Expenses	N/A	f. g.
Surplus after Reserve Funding and Capital Purchase Adjustments	\$ 428,596	Gross Surplus		Pg. 48
Adjustments	\$ -			
Surplus Available for Transfer	\$ 428,596			Pg. 48

GVR
Long Term Capital Project Plan
Cash Funding Projections

All Amounts Are Projections

Initiatives	2023	2024	2025	2026	2027
Beginning Balance	\$ 2,531,557	\$ 446,272	\$ 913,963	\$ 1,692,274	\$ 2,544,937
Funding From Operations Revenue	\$ 643,584	\$ 626,088	\$ 635,987	\$ 664,930	\$ 646,325
Additional GVR Funding (Surplus)	\$ 428,596	\$ 100,000	\$ 100,000	\$ 100,000	\$ 100,000
Transfer to Operations	\$ (90,827)				
Loan Payments					
Net Investment Earnings	\$ 147,699	\$ 26,037	\$ 53,323	\$ 98,732	\$ 148,479
Projects:					
West Center Arts Center	\$ (50,000)				
Del Sol Club House	\$ (980,006)				
Canoa Hill Parking Lot Note	\$ (11,000)	\$ (11,000)	\$ (11,000)	\$ (11,000)	\$ (11,000)
Santa Rita Springs Glass Arts	\$ (734,232)				
SRS Kino Room / Computer Lab	\$ -				
Social Gathering Place	\$ (50,000)				
Desert Hills Fitness Expansion	\$ (913,695)				
2nd Pmt DH Fitness Equipment	\$ (75,404)				
Desert Hills Ceramics Expansion					
Expand Ceramics	\$ (200,000)				
ABS Shuffleboard Courts		\$ (123,433)			
Unbudgeted Security System	\$ (200,000)				
LC Third Tennis Courts		\$ (150,000)			
Ending Balance	\$ 446,272	\$ 913,963	\$ 1,692,274	\$ 2,544,937	\$ 3,428,741
Maintenance Repair & Replacement					
Beginning Balance	\$ 7,043,208	\$ 7,172,933	\$ 6,799,653	\$ 7,292,460	\$ 7,588,381
Annual Funding (per Reserve Study)	\$ 1,179,940	\$ 1,320,420	\$ 1,426,054	\$ 1,540,138	\$ 1,540,138
Additional Funding					
Net Investment Earnings (actual IPS rate)	\$ 602,423	\$ 661,779	\$ 594,991	\$ 654,617	\$ 358,822
Projects:					
Per Reserve Study	\$ (1,652,638)	\$ (2,355,479)	\$ (1,528,237)	\$ (1,898,835)	\$ (1,035,850)
Ending Balance	\$ 7,172,933	\$ 6,799,653	\$ 7,292,460	\$ 7,588,381	\$ 8,451,490
MRR Part B - Pools and Spas					
Beginning Balance	\$ 576,962	\$ 727,408	\$ 1,091,452	\$ 1,492,815	\$ 72,975
Funding	\$ 289,405	\$ 303,875	\$ 319,069	\$ 335,022	\$ 351,774
Additional Funding (2022 Surplus allocation)	\$ -				
Net Investment Earnings	\$ 50,546	\$ 60,168	\$ 82,294	\$ 106,641	\$ 24,781
East Center Pool	\$ (189,505)				
Casa Paloma 1 (or other pool)				\$ (1,861,503)	
Ending Balance	\$ 727,408	\$ 1,091,452	\$ 1,492,815	\$ 72,975	\$ 449,530
Subtotal Capital Projects Reserves	\$ 8,346,613	\$ 8,805,068	\$ 10,477,549	\$ 10,206,293	\$ 12,329,761

GVR
Long Term Capital Project Plan
Cash Funding Projections

All Amounts Are **Projections**

	2023	2024	2025	2026	2027
Emergency					
Beginning Balance	\$ 490,701	\$ 523,877	\$ 559,297	\$ 587,297	\$ 616,297
Annual Funding	\$ -	\$ -	\$ -	\$ -	\$ -
Transfer to Initiative					
Net Investment Earnings	\$ 33,176	\$ 35,419	\$ 28,000	\$ 29,000	\$ 31,000
Projects:					
East Center (2019)					
Ending Balance	\$ 523,877	\$ 559,297	\$ 587,297	\$ 616,297	\$ 647,297
Total Board Designated Funds	\$ 8,870,490	\$ 9,364,364	\$ 11,064,846	\$ 10,822,589	\$ 12,977,058



Green Valley Recreation, Inc.

Board of Directors Regular Meeting

Award Contract to Preventronics Security Cameras

Prepared By: Randy Cheatham, IT Director

Meeting Date: April 26, 2023

Presented By: Scott Somers, CEO

Consent Agenda: No

Originating Committee / Department:

IT Department in collaboration with the office of the COO and the Facilities Director.

Action Requested:

Award contract to Preventronics for security camera provision and installation, not to exceed \$200,000, and authorize the President to sign the contract.

Strategic Plan Goal:

Goal 1: Provide excellent facilities for members to participate in a variety of active and social opportunities.

Background Justification:

Security concerns have thankfully not been a historical concern at GVR. However, it is a different time than before, and with a recent intrusion at Las Campanas, staff and others agree that increased security is needed to ensure a safer environment for all GVR members, guest, and visitors. Security cameras placed in strategic locations (e.g., parking lots, points of entry, walkways) can help deter nefarious activity as well as help provide evidence during an investigation and Code of Conduct allegations.

Staff issued a request for proposals (RFP) and received bids from three vendors: Preventronics, Titan Alarm, and Johnson Controls for security cameras covering 14 centers, the Administrative Office, the Pickleball Center, the Del Sol Clubhouse, and the Facility Maintenance Building. Staff also priced similar cameras with a well-known online vendor, Verkada. After meeting with each local company and explaining the scope of work, each of the three local companies submitted bids. Verkada's pricing for the cameras alone (less labor, less misc. switching and cabling, less yearly licensing) was much more costly and dropped from consideration.

Preventronics is GVR's current vendor for all DSX access control systems that operate all of the doors and gates. Their staff is familiar with every center throughout the campus and the needs and expectations of the GVR community.

Staff therefore recommends awarding a contract to Preventronics for security camera provision and installation, not to exceed \$200,000. While the contract price is for \$153,729, staff recommends allowing for additional contingency to cover unexpected costs or additional cameras should the need be warranted without the need to come back to the Board recommending a change order.

Fiscal Impact:

This capital expense was not budgeted. Staff recommends funds for this project be expended from the Initiatives Funds. Annual cost to maintain this system is \$15,373 and would be budgeted as an operational expense going forward. Maintenance includes:

- 4-hour service response time between 6am-6pm, M-F.
- Top priority service calls.
- Bi-annual inspections of all hardware/software and database maintenance.
- Software upgrades as necessary.
- All parts. (1 years)
- All labor. (1 years)
- Use of spare equipment to minimize downtime.

Board Options:

1. Approve the GVR staff recommended contract with Preventronics to install cameras at all facilities in strategic locations at a cost not to exceed \$200,000, and authorize the President to sign the contract.
2. Approve the GVR staff recommended contract with Preventronics to install cameras at all facilities in strategic locations at a cost not to exceed a different amount, and authorize the President to sign the contract.
3. Direct staff to pursue less expensive options with fewer cameras, not to exceed a certain limit.
4. Direct staff to do nothing with cameras at this time.

Staff Recommendation:

Option #1

Recommended Motion:

Move to Award contract to Preventronics for security camera provision and installation, not to exceed \$200,000, and authorize the President to sign the contract.

Attachments:

Draft Contract with Preventronics
Proposal Summary
Incident Examples

GREEN VALLEY RECREATION CENTERS

Project:

GVR - All Locations Camera System

Project Location:

GVR - Main Office

**1070 S. Calle de Las Casitas
Green Valley, AZ 85614**

February 16, 2023

Presented to

Randy Cheatham
GVR Board of Directors

Prepared by

Spence Bledsoe
Mobile (520) 500-6005
Desk (520) 790-4960
sbledsoe@preventronics.com

Pre-venTronics

February 16, 2023

GVR Board of Directors
1070 S. Calle de Las Casitas
Green Valley, AZ 85614

Dear Board of Directors,

We are pleased to have the opportunity to provide this proposal for consideration.

Proposal Contents

This proposal is composed as follow:

- Section I Location Summary
- Section II Scope of Work
- Section III Investment Summary
- Section IV Maintenance Program
- Section V..... Conclusion

Section I. – Location Summary

Quote 903087-34 Santa Rita Springs
Quote 903087-35 West Center
Quote 903087-36 Member Services
Quote 903087-37 Madera Vista
Quote 903087-38 Las Campanas Social Center
Quote 903087-39 Desert Hills Social Center
Quote 903087-40 East Social Center
Quote 903087-41 Continental Vista
Quote 903087-42 Casa Paloma I
Quote 903087-43 Canoa Ranch Rec Center
Quote 903087-44 Casa Paloma II
Quote 903087-45 Canoa Hills Rec Center
Quote 903087-46 Abrego South
Quote 903087-47 Abrego North
Quote 903087-48 Facilities Maintenance Building
Quote 903087-49 Pickleball Court
Quote 903087-50 West Center Pool
Quote 903087-51 New Building

Section II. – Scope of Work

The solution is comprised of the following design with Digital Watchdog equipment:
Each Quote itemizes camera counts per location indicating indoor or outdoor.
Some sites will send camera video to other sites NVR's to reduce cost and maintain quality across GVR networks

Quotes include (123) 2.1 Megapixel low profile IR Indoor/Outdoor cameras, POE switches as needed per site and (6) 64 Channel 6TB Hard drive servers. All CAT6e wire, camera licenses and labor.

All cameras can be viewed by GVR staff as needed on GVR network. GVR IT shall manage access to all systems. PVT will work with GVR Staff on installation and specific location of equipment.

Section III. – Investment Summary

903087-34 SANTA RITA SPRINGS	-14	\$16,994.21
903087-35 WEST CENTER	-14	\$18,449.74
903087-36 MEMBER SERVICES	-6	\$5,807.03
903087-37 MADERA VISTA	-5	\$4,761.02
903087-38 LAS CAMPANAS SOCIAL CENTER	-13	\$15,000.01
903087-39 DESERT HILLS SOCIAL CENTER	-11	\$15,576.93
903087-40 EAST SOCIAL CENTER	-10	\$8,621.13
903087-41 CONTINENTAL VISTA	-3	\$3,700.17
903087-42 CASA PALOMA I	-3	\$3,203.27
903087-43 CANOA RANCH RECREATION CENTER	-7	\$12,444.56
903087-44 CASA PALOMA II	-4	\$5,160.90
903087-45 CANOA HILLS RECREATION CENTER	-8	\$13,822.91
903087-46 ABREGO SOUTH	-5	\$5,237.80
903087-47 ABREGO NORTH	-2	\$3,113.49
903087-48 FACILITIES MAINTANCE BUILDING	-4	\$5,095.00
903087-49 PICKLEBALL COURT	-5	\$5,970.16
903087-50 WEST CENTER POOL	-4	\$5,133.55
903087-51 NEW BUILDING	-5	\$5,636.92
	Cameras-123	
TOTAL COST: (includes sales tax)		\$153,728.80

Section IV. –OPTIONAL Maintenance Plan (not included)

We are pleased to offer our "OPTIONAL" annual **FSP** (Full-Service Plan) designed to protect the 'critical and automated' operation the above system provides as follows.

- ❖ **Full Service Plan: \$15,373.00 /annually** (Billable monthly at start of each month)
- ❖ IF CHOSEN - The FSP would begin upon completion of PVT's installation for the term of ONE YEAR. With this full service plan in place GVR would receive top priority service/maintenance as noted in the yellow FSP Coverage column VERSUS our Standard Warranty Service noted under Standard Warranty.
- ❖ **TERM AND RENEWAL:** This FSP will commence on the date of completion and shall be effective for one year. This Agreement shall automatically be renewed for one-year terms. Provided however, either party may terminate this Agreement at any time with or without cause by sending the other party at least thirty (30) days' prior written notice of termination. In the event the Corporation terminates this Agreement, it shall be understood that the cost of the Agreement will be prorated on a monthly basis and the Corporation will be refunded any amounts for any months paid by the Corporation for services that will not be performed because of the termination.

Plan Benefits for the above are:

Benefits	FSP Coverage	Standard Warranty
Availability:	M – F / 6am – 6pm 4-HR response time	Next business day and/or as soon as possible. FSA customers are prioritized first. After *Standard Warranty expires, any service is under Time & Material basis.
Response Time:	4 hours or less. From time service call is placed.	Next business day, and/or as soon as possible. FSA customers are prioritized first. After *Standard Warranty expires, any service is under Time & Material basis.
Response Status:	Top Priority. Over non-FSP clients.	Next business day, and/or as soon as possible. FSA customers are prioritized first. After *Standard Warranty expires, any service is under Time & Material basis.
Preventative Maintenance:	Included. Bi-Annual Inspections of hardware and software including database maintenance.	Time & Material. (not included)
Software Upgrades:	Covers software upgrades related to defects and software modifications necessary to correct system issues.	Time & Material. (not included)
Parts Coverage:	All parts are covered. No hidden costs, on all parts we provide and install for one year.	Only under manufacturers' warranty period after which replacements are new purchases.
Labor Coverage:	All labor is covered. No hidden costs, for service rendered during standard and emergency times.	After *Standard Warranty expires (90 Days), any labor is billed on a per hour basis + materials + travel.
Spare Equipment:	Available PVT will keep (3) cameras and (1) NVR in stock for GVR service on hand to ensure downtime is kept to an absolute minimum. Any add'l equipment	Equipment is dependent on product availability with MFG since FSA customers take priority for these resources.

	needed will be ordered Next Day at no charge.	
--	---	--

Items Not Covered: Any damage caused by misuse, abuse, vandalism, accident, disaster, fire, flood, water, wind, lighting and Acts of God. Also, any items designed to fail in order to protect equipment, such as power/lightening suppressors, UPS's.

INSURANCE: (COI attached)

During the term of this Contract, Pre-venTronics shall maintain the amounts and types of insurance described herein. Pre-venTronics shall provide Green Valley Recreation, Inc. with certificates evidencing all insurance coverages in place, which shall at a minimum meet the coverages required hereunder and shall name the following as additional insureds: Green Valley Recreation, Inc. and its successors and assigns, directors, officers, managers, trustees, trust beneficiaries, agents, and employees (collectively, "Additional Insureds"). Insurance coverage consists of Workman Compensation insurance in the amount required by Arizona Law, Commercial General Liability insurance in an amount no less than \$1,000,000 per occurrence, \$1,000,000 Personal Injury and Advertising Injury, and \$1,000,000 General Aggregate and a deductible of no more than \$5,000 per occurrence; Excess Liability insurance in an amount no less than \$1,000,000.

INDEMNIFICATION: (Note overrides the hold harmless and indemnification on Quotes)

To the fullest extent permitted by law, Pre-venTronics shall indemnify, protect, defend and hold harmless the Green Valley Recreation, Inc, its respective directors, officers, partners, agents, employees, managers, trustees, and any successors or assigns of any of the foregoing for, from and against any and all claims, suits, actions, proceedings, losses, liabilities or expenses (including without limitation attorneys' fees and all court costs and other expenses) arising out of or in connection with any negligent or intentional act or omission of Pre-venTronics (or any of its employees, agents, contractors or subcontractors) otherwise pertaining in any manner to this Contract including but not limited to the installation, use, or functioning of the equipment. It is understood and agreed that the foregoing provisions of this paragraph shall survive the termination of this agreement or the installation of the equipment.

DISPUTE RESOLUTION:

If either party brings legal action to enforce the terms of this Contract, the action shall be brought in Superior Court in Pima County, Arizona. The prevailing party shall be entitled to its attorneys' fees and costs, and any monetary damages awarded by the Court.

Section V. – Conclusion

If during our installation customer decides to make changes or additions to equipment proposed, additional charges for labor or materials will be created on a Change Order quote. Our proposed system includes all equipment and labor to accomplish the system design in each Quote attached.

Thank you for the opportunity to be of service to you, as we know you have many choices for a solutions-provider and business-partner. With this project, it is our sincere intention to deliver a world class solution and to nurture a long-term relationship based on caring and integrity.

Should you have any questions, please do not hesitate to call me.

Sincerely,



Spence Bledsoe
Project Manager
PrevenTronics
(520) 500-6005

Blackjack[®] CUBE

Servers Powered by DW Spectrum[®] IPVMS

HD IP Video Management Solution Blackjack[®] Cube™
DW-BJCUBE



NDAA/TAA
COMPLIANT PRODUCTS

Dimensions

unit: inch (mm)

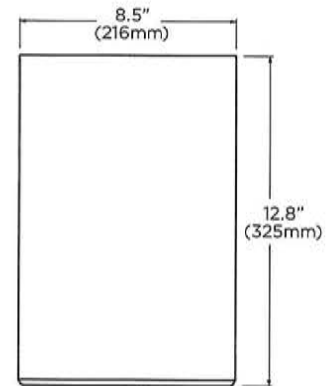
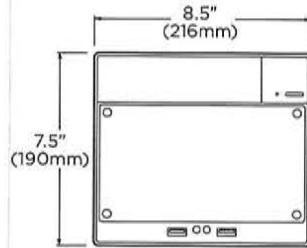

3-18TB Storage
 Record up to 64 IP Cameras
 HD Output
 Two NIC Cards
 DW Spectrum IPVMS
 5 YEAR Limited Warranty

Summary

The Blackjack[®] Cube™ server can record and manage single-sensor IP cameras of any resolution, with a maximum of 360Mbps throughput. The hardware includes DVI-D/DVI-I outputs, Windows[®] 10 IoT OS, and dual network card. The server is ONVIF conformant and is available with 3-18TB HDD and 5 year limited warranty.

Features

- Supports all ONVIF conformant IP cameras
- Record and manage single- and multi-sensor IP cameras of any resolution up to maximum 360Mbps throughput
- Storage options 3-18TB internal storage
- DVI-D or true HD video output
- Dual network ports
- Windows[®] 10 IoT OS
- Hosting DW Spectrum[®] IPVMS for setup, configuration, monitoring and recording
- One-time recording license charge, fully transferable between cameras and encoders
- One (1) DW Spectrum[®] IPVMS 4-channel licenses included (DW-SPECTRUMLS004)
- No annual maintenance fees
- Simple enterprise scalability
- Auto device discovery
- Dual stream recording
- 5 year limited warranty



Available models

- ~~DW-BJCUBE3T - 3TB storage~~ • ~~DW-BJCUBE9T - 9TB storage~~
- ~~DW-BJCUBE4T - 4TB storage~~ • ~~DW-BJCUBE12T - 12TB storage~~
- ~~DW-BJCUBE6T - 6TB storage~~ • ~~DW-BJCUBE18T - 18TB storage~~

Specifications

Included IP licenses	4	
Form factor	Desktop	
Operating system	Windows [®] 10 IoT	
CPU	Intel [®] i5 [®] processor	
Memory	16GB	
NIC	2x gigabit ethernet (RJ45)	
System	Max video storage rate (Mbps)	360 Mbps
Storage	Maximum hard drives	3 x SATA HDD
	Maximum storage	18TB
Video-out	Outputs	DVI-D or true HD output
	Resolution	HD 1080p
Preloaded VMS software	DW Spectrum [®] IPVMS	
Unlimited remote clients	Cross platform - Windows [®] , Linux [®] and Mac [®]	
Mobile apps	iOS [®] and Android [®]	
Keyboard and mouse	Included	
Power	300W**	
Voltage	AC input: 100-240Vac 6-3A 60-50Hz	
	DC output: +12V1 16A +12V2 16A +5V 15A +3.3V 12A +5Vsb 2A -12V 0.3A	
Operating temperature and humidity	41°F-104°F (5°C-40°C) / 20-90% RH	
Dimension (WxDxH) (inches)	8.5" x 12.8" x 7.5" (215.9 x 325.1 x 190.5 mm)	
Warranty	5 year limited	

* Available at time of initial order only / ** UPS recommended

Designed and Commissioned in the U.S.A.



Increase sales and profitability. Sign up and become a DW Channel Partner today!



☎: 866.446.3595

✉: sales@digital-watchdog.com

🌐: www.digital-watchdog.com





2.1MP Resolution
2.8mm Fixed Lens
H.265 H.264/MJPEG Triple Codecs
Smart IR™
IP67 Rated
5 YEAR Warranty

Dimensions
unit: Inch (mm)

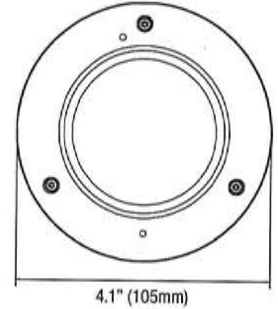
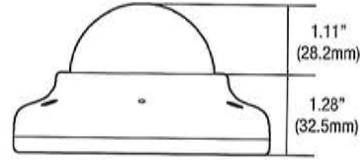

Summary

This MEGApix® IP camera provides 2.1MP/1080p resolution at real-time 30fps. It includes a 2.8mm fixed lens and simultaneous H.265/H.264/MJPEG codec support. The IP67-rated, IK-10 impact-resistant ultra low-profile vandal dome camera brings the capabilities of a robust camera in a small and discrete housing. All MEGApix® cameras are ONVIF conformant, assuring their successful integration with any open platform solution on the market.

Features

- 2.1MP/1080p 1/2.9" image sensor at real-time 30fps
- 2.8mm fixed lens
- Digital Wide Dynamic Range (D-WDR)
- Triple codecs (H.265, H.264, MJPEG) with simultaneous streaming
- 80' Smart IR™ with intelligent camera sync
- Ultra low-profile vandal dome camera housing
- Smart DNR™ 3D digital noise reduction
- True day/night mechanical IR cut filter
- Programmable privacy zones
- Auto gain control (AGC)
- Backlight compensation (BLC)
- Auto white balance (AWB)
- Motion detection
- Web server built-in
- PoE class 2 and DC12V
- Waterproof cabling
- UL listed
- ONVIF conformant, profile S
- IP67 dust-tight and waterproof to 3 feet
- IK 10-rated impact-resistant
- 5 year warranty



Specifications



IMAGE	
Image sensor	2.1MP/1080p 1/2.9" CMOS
Total pixels	2001 (H) X 1121 (V)
Minimum scene illumination	0.16 lux (color) 0.0 lux (B/W)
LENS	
Focal length	2.8mm, F1.6
Lens type	Fixed lens
Field of view (FoV)	103°
IR distance	80ft range
OPERATIONAL	
Shutter mode	Auto, manual, anti-flicker, slow shutter
Shutter speed	1/15 - 1/32000
Slow shutter	2X, 3X, 5X, 6X, 7.5X, 10X
Auto gain control	Auto
Day and night	Auto, day (color), night (B/W)
Smart DNR™ 3D digital noise reduction	3D-DNR
Wide Dynamic Range (WDR)	D-WDR
Privacy zone	16 programmable privacy masks
Backlight Compensation (BLC)	Yes
Mirror & flip	Yes
Alarm notifications	Notifications via e-mail and FTP server recording
NETWORK	
LAN	RJ45 (10/100Base-T)
Video compression type	H.265, H.264, MJPEG
Resolution	H.265: 2.1MP/1080p, 720p (main), CIF (sub) H.264: 2.1MP/1080p, 720p (main), CIF (sub) MJPEG: CIF
Frame rate	Up to 30fps at all resolutions
Video bitrate	100Kbps - 10Mbps, multi-rate for preview and recording
Bitrate control	Multi streaming CBR/VBR at H.264, H.265 (controllable frame rate and bandwidth)
Streaming capability	Dual-stream at different rates and resolutions
IP	IPv4, IPv6
Protocol	TCP/IP, UDP, AutoIP, RTP (UDP/TCP), RTSP, NTP, HTTP, HTTPS, SSL, DNS, DDNS, DHCP, FTP, SMTP, ICMP, SNMPv1/v2/v3 (MIB-2), ONVIF
Security	HTTPS (SSL), IP filtering, 802.1x, digest authentication (ID/PW)
ONVIF conformance	Yes
Web viewer	OS: Windows®, Mac® OS, Linux® Browser: Internet Explorer®, Google Chrome®, Mozilla Firefox®, Safari®
Video management software	DW Spectrum® IPVMS
ENVIRONMENTAL	
Operating temperature	-4°F - 122°F (-20°C - 50°C)
Operating humidity	10-90% (non-condensing)
IK Rating	IK10 impact resistant
IP Rating	IP67-rated
Other certifications	UL listed, CE, FCC, RoHS
ELECTRICAL	
Power requirement	DC 12V, PoE IEEE 802.3af Class 2. (Adapter not included)
Power consumption	DC12V: max 3.7W PoE: max 5.4W
MECHANICAL	
Material	Aluminum vandal housing, polycarbonate dome
Dimensions	4.13" x 2.4" (105 x 61mm)
Weight	0.88lbs (0.4kg)
Warranty	5 year warranty

Accessories (Optional)



DWC-V7WM
Wall mount
bracket



DWC-V7JUNC
Junction box



DWC-V7DECO
5x decorative
rings



DWC-V7CM
Ceiling mount
bracket



2.1MP Resolution
IVA+ Intelligent Video Analytics (IVA+)
Star-Light Plus™
2.8, 4.0mm Fixed Lens Options
Built-in Microphone
5 YEAR Warranty

Summary

This MEGAPIX IVA+™ IP camera is your gateway to powerful video analytics features. It is NDAA compliant and provides 2.1MP/1080p resolution at real-time 30fps and the convenience of audio input through built-in microphone. The MEGAPIX IVA+ cameras have a powerful engine to detect and classify people, vehicles and objects in real-time with support for logical rules. This camera includes 2.8 and 4.0mm fixed lens options, simultaneous H.265/H.264/MJPEG codec support and Star-Light Plus™ color in near-total darkness technology for quality video in any lighting condition, all in an IP67-rated, IK-10 impact resistant ultra low-profile vandal dome housing. All MEGAPIX cameras are ONVIF conformant, assuring their successful integration with any open platform solution on the market.

Features

- 2.1MP/1080p 1/2.8" image sensor at real-time 30fps
- Star-Light Plus™ color in near-total darkness technology
- Intelligent Video Analytics (IVA) with extended features (IVA+)
- Seamless integration and control of IVA rules with DW Spectrum® IPVMS
- Reduce false alarms
- Increase your recording storage with logic rules and smart recording
- 2.8mm fixed lens (DWC-MPV72Wi28ATW)
- 4.0mm fixed lens (DWC-MPV72Wi4ATW)
- True Wide Dynamic Range (WDR)
- Triple codecs (H.265, H.264, MJPEG) with simultaneous streaming
- 80° Smart IR™ with intelligent camera sync
- Ultra low-profile vandal dome camera
- Smart DNR™ 3D digital noise reduction
- True day/night mechanical IR cut filter
- Programmable privacy zones
- Auto gain control (AGC)
- Auto white balance (AWB)
- Motion detection
- Audio input through built-in microphone
- Micro SD/SDHC/SDXC class 10 card slot (card not included)
- PoE class 2 and DC12V
- UL listed
- NDAA compliant
- IP67 dust-tight and waterproof to 3 feet
- IK 10-rated impact-resistant
- 5 year warranty



Dimensions

Unit: Inch (mm)

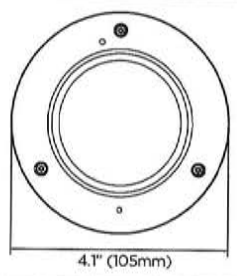
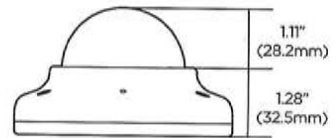

Specifications



IMAGE	
Image sensor	2.1MP/1080p 1/2.8" CMOS
Total pixels	1945 (H) X 1109 (V)
Minimum scene illumination	0.05 lux (color) (DWC-MPV72Wi28ATW) 0.09 lux (color) (DWC-MPV72Wi4ATW) 0.0 lux (B/W)
LENS	
Focal length	2.8mm, F2.0 (DWC-MPV72Wi28ATW) 4.0mm, F2.6 (DWC-MPV72Wi4ATW)
Lens type	Fixed lens
HFOV / VFOV	111° / 62° (DWC-MPV72Wi28ATW) 86° / 46° (DWC-MPV72Wi4ATW)
IR distance	80ft range
I/O	1 (microphone built-in) / 0 outputs, G, 7/11
Audio in / out, compression	NOTE: The camera should be installed approximately 3-6ft (1-2 meters) from a person speaking in a normal tone (50-60 dB).
OPERATIONAL	
Intelligent Video Analytics	IVA: intrusion, line crossing, counting line, loitering, enter, exit, tamper IVA+: object removed, tailgating, direction, stopped, appear, disappear, object left, logical rules
Shutter mode	Auto, manual, anti-flicker, slow shutter
Shutter speed	1/15 - 1/32000
Slow shutter	1/2, 1/3, 1/5, 1/6, 1/7.5, 1/10
Auto gain control	Auto
Day and night	Auto, day (color), night (B/W)
Smart DNR™ 3D Digital Noise Reduction	3D-DNR
Wide Dynamic Range (WDR)	True WDR, 120dB
Privacy zones	16 programmable privacy masks
Mirror and flip	Yes
Alarm notifications	Notifications via e-mail notifications, FTP and SD card recording
Memory slot	Micro SD / SDHC / SDXC (card not included)
NETWORK	
LAN	RJ45 (10/100Base-T)
Video compression type	H.265, H.264, MJPEG
Resolution	H.265: 2.1MP/1080p, 720p, VGA, D1, CIF H.264: 2.1MP/1080p, 720p, VGA, D1, CIF MJPEG: 1280x720, 800x600, VGA, 768x432, D1, CIF
Frame rate	Up to 30fps at all resolutions
Video bitrate	100Kbps - 10Mbps, multi-rate for preview and recording
Bitrate control	Multi-streaming CBR/VBR at H.264, H.265 (controllable frame rate and bandwidth)
Streaming capability	Dual-stream at different rates and resolutions
IP	IPv4, IPv6
Protocol	TCP/IP, UDP, AutoIP, RTP (UDP/TCP), RTSP, NTP, HTTP, HTTPS, SSL, DNS, DDNS, DHCP, FTP, SMTP, ICMP, SNMPv1/v2/v3 (MIB-2), ONVIF
Security	HTTPS (TLS), IP filtering, 802.1x, digest authentication (ID/PW)
ONVIF conformance	Yes
	OS: Windows®, Mac® OS, Linux®
Web viewer	Browser: Internet Explorer®, Google Chrome®, Mozilla Firefox®, Safari® NOTE: Chrome browser is recommended for IVA configuration
Video management software	DW Spectrum® IPVMS
ENVIRONMENTAL	
Operating temperature	-4°F - 122°F (-20°C - 50°C)
Operating humidity	10-90% (non-condensing)
IP and IK rating	IP67-rated, IK10 impact resistant
Other certifications	UL listed, CE, FCC, RoHS
ELECTRICAL	
Power requirement	DC 12V, PoE IEEE 802.3af Class2. (Adapter not included)
Power consumption	DC12V: max 3.7W PoE: max 5.5W
MECHANICAL	
Material	Aluminum vandal housing, polycarbonate dome
Dimensions	4.13" x 2.4" (105 x 61mm)
Weight	0.79 lbs (0.36kg)
Warranty	5 year warranty

Accessories (optional)



☎ : 866.446.3595

✉ : sales@digital-watchdog.com

🌐 : www.digital-watchdog.com



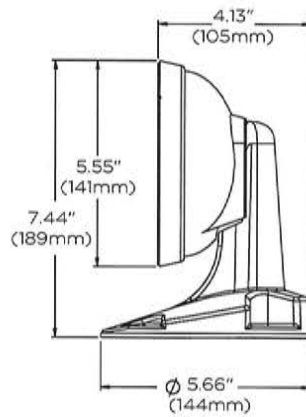
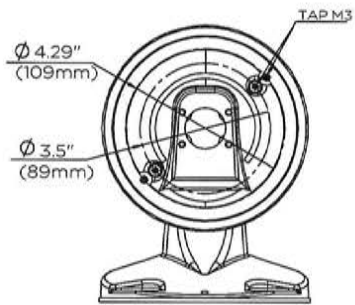
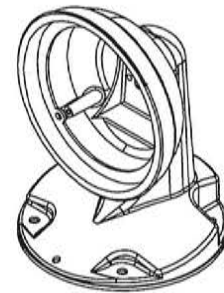
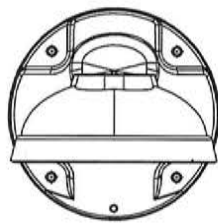

Mounting screws (4 each)

Mounting screws (4 each)

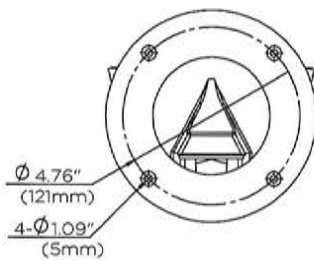
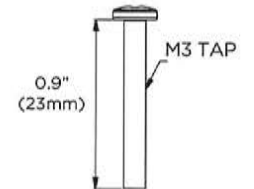
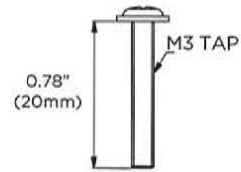

DATE	SCALE	MATERIAL	TYPE
01/2022		Aluminum	Fixed
		DESCRIPTION DW-C-VFWMW Wall mount bracket for white IP vandal dome cameras	

Pre-venTronics

a division of Circuit-Tron Corporation
ROC 093244 CR67

PRE-VENTRONICS
1635 S. ALVERNON WAY
TUCSON, AZ 85711
TEL: (520) 790-4960
FAX: (520) 790-7816

SALES QUOTE

DATE 2/15/2023

**QUOTE#903087 - 34-
GVR CAMERA
SYSTEM- SANTA RITA
SPRINGS-REV-2**

SHIP TO	BILL TO
GVR - MAIN OFFICE 1070 S. CALLE DE LAS CASITAS GREEN VALLEY, AZ 85614	GREEN VALLEY RECREATION ASSOC.

PROJECT
GVR CAMERA SYSTEM- SANTA RITA SPRINGS-REV-2

DESCRIPTION	UNIT PRICE	QTY	LINE TOTAL
GVR CAMERA SYSTEM- SANTA RITA SPRINGS-REV-2			
4 PARKING LOT CAMERAS-10 EXTERIOR CAMERAS			
64 CHANNEL, NVR WITH 4TB HDD. THE NVR RECORDS AND MANAGES UP TO 64 IP CAMERAS WITH A TOTAL THROUGHPUT OF 360 MBPS. THE HARDWARE INCLUDES THE HARDWARE SUPPORTS TRUE HDMI LOCAL OUTPUT VIA DVI-D/DVI-I PORTS, I5 PROCESSOR, DUAL NETWORK CARD AND SCHEDULED AUTO REBOOT FOR HARDWARE PERFORMANCE. THE NVR SUPPORTS CROSS PLATFORM CONNECTIVITY FOR WINDOWS AND MAC CLIENT SOFTWARE, ALLOWING YOU TO MONITOR AND CONNECT TO YOUR SYSTEM FROM ANYWHERE.		1	\$2,781.78
16-PORT GIGABIT POE+ NETWORK SWITCH 120WATTS POWER		1	\$286.28
MEGAPIX 2.1MP ULTRA-LOW-PROFILE IR OUTDOOR DOME CAMERA, 2.8MM FIXED LENS	\$325.15	14	\$4,552.05
WALL MOUNT BRACKET FOR EXTERIOR CAMERAS	\$43.25	8	\$345.96
SINGLE RECORDING LICENSE	\$106.03	14	\$1,484.42
CAT6E 23-4P UNS SOL CMR RISER PURPLE 1K	\$212.06	6	\$1,272.35
MISC MATERIAL		1	\$583.17
LABOR FOR INSTALLATION		1 LOT	\$4,998.54
		PARTS	\$11,306.00
		LABOR	\$4,998.54
		TAXES	\$689.67
		SHIPPING	
		TOTAL	\$16,994.21

Quote pricing is valid for 30-Days from date on quote.

CREDIT CARD PAYMENTS WILL INCUR A 3.5% PROCESSING FEE ADDED TO TOTAL CONTRACT

TERMS & CONDITIONS:

ACCEPTANCE OF THIS SALES QUOTE IS SUBJECT TO AGREEMENT BY CUSTOMER TO THE FOLLOWING CONDITIONS:

- WORK IS TO BE PERFORMED DURING NORMAL WORKING HOURS, M-F / 7-5.
- ONLY EQUIPMENT LISTED ABOVE SHALL BE INSTALLED AND WARRANTED BY PRE-VENTRONICS.
- PAINTING, PATCHING ARE EXCLUDED.
- 110 VOLT POWER TO BE PROVIDED BY OTHERS.
- PROPOSAL INCLUDES EQUIPMENT AS LISTED BASED ON DESIGN INFORMATION AVAILABLE AT TIME OF PROPOSAL. ADDITIONAL EQUIPMENT AND DESIGN CHANGES WILL BE QUOTED AND BILLED AS CHANGE ORDERS.
- STANDARD WARRANTY - PRE-VENTRONICS PROVIDES A 1 YEAR WARRANTY ON PARTS AND 90-DAYS ON LABOR FOR THE INSTALLATION OF THE ABOVE SYSTEM. WARRANTY SERVICES ARE PROVIDED DURING NORMAL BUSINESS HOURS, MONDAY THROUGH FRIDAY, 7:00 AM TO 5:00 PM (EXCLUDING HOLIDAYS). EMERGENCY RESPONSE DURING PREMIUM HOURS AND HOLIDAYS WILL BE CHARGED AT THE PREVAILING SERVICE RATES.
- ALL INVOICES ARE DUE AND PAYABLE TO PRE-VENTRONICS UPON RECEIPT.
- THE CUSTOMER AGREES TO HOLD HARMLESS AND INDEMNIFY PRE-VENTRONICS FROM ANY LOSS, DAMAGE AND/OR LITIGATION EXPENSE ARISING FROM ANY CLAIM OF INFRINGEMENT OF ANY PATENT, BY THE USE OR MANUFACTURE BY ANY ARTICLE FURNISHED TO IT BY THE SELLER UNDER THIS ORDER.
- MATERIALS NOT EXPLICITLY LISTED HEREIN ARE "BY OTHER" AND ARE EXCLUDED FROM THIS SCOPE OF WORK. NO ASSUMPTIONS SHOULD BE MADE REGARDING WHAT MATERIALS WILL BE PROVIDED, OTHER THAN WHAT IS LISTED IN THE ABOVE DESCRIPTION.

EXCEPTIONS:

- ACTS OF GOD AND OR TERRORISM ARE BEYOND OUR CONTROL AND PRE-VENTRONICS IS NOT RESPONSIBLE FOR THESE ACTS OR AS TO THE IMPACT THAT THEY MAY HAVE ON THIS SCOPE OF SERVICES OR DELIVERED PRICING.
- EXTRA LABOR COSTS IF INSTALLATION NEEDS TO TAKE PLACE AFTER NORMAL BUSINESS HOURS, WEEKENDS, OR HOLIDAYS.
- EXTRA COSTS FOR EXPEDITING OF PRODUCTS AND INSTALLATION.
- WARRANTY OF COMPONENTS NOT SUPPLIED BY PRE-VENTRONICS. REPAIRS AND/OR REPLACEMENTS WILL BE DONE ON A TIME AND MATERIALS BASIS UPON APPROVAL OF THE WORK.
- EXTRA COSTS FOR MATERIALS AND LABOR NOT INCLUDED IN THE ABOVE SCOPE OF SERVICES.
- EXTRA COSTS FOR INSURANCE REQUIREMENTS THAT EXCEED PRE-VENTRONICS STANDARD PROVISIONS OF 2M OR WAIVER OF SUBROGATION.
- CONDITION AND INTEGRITY OF EXISTING SITE.

WE APPRECIATE THE OPPORTUNITY TO PROVIDE OUR PROPOSAL FOR YOUR CONSIDERATION ON THIS PROJECT. PRE-VENTRONICS STRIVES TO BE A LEADER IN THE MARKET BY USING ONLY THE BEST AND LATEST PRODUCT ACCOMPANIED WITH HIGHLY QUALIFIED AND TRAINED TECHNICIANS FOR INSTALLATION AND SERVICE. YOU WILL DISCOVER THIS FIRSTHAND WHEN YOU CHOOSE US TO ASSIST YOU IN THIS PROJECT.



Spence Bledsoe, Project Manager

TEL:
sbledsoe@preventronics.com

CUSTOMER SIGNATURE DATE

PO NUMBER AMOUNT

Pre-venTronics

a division of Circuit-Tron Corporation
ROC 093244 CR67

PRE-VENTRONICS
1635 S. ALVERNON WAY
TUCSON, AZ 85711
TEL: (520) 790-4960
FAX: (520) 790-7816

SALES QUOTE

DATE 2/15/2023
**QUOTE#903087 - 35-
GVR CAMERA
SYSTEM- WEST
CENTER REV-2**

SHIP TO	BILL TO
GVR - MAIN OFFICE 1070 S. CALLE DE LAS CASITAS GREEN VALLEY, AZ 85614	GREEN VALLEY RECREATION ASSOC.

PROJECT
GVR CAMERA SYSTEM- WEST CENTER REV-2

DESCRIPTION	UNIT PRICE	QTY	LINE TOTAL
GVR CAMERA SYSTEM- WEST CENTER REV-2			
5 PARKING LOT CAMERAS-8 EXTERIOR CAMERAS-1 INTERIOR CAMERA			
64 CHANNEL, NVR WITH 6TB HDD. THE NVR RECORDS AND MANAGES UP TO 64 IP CAMERAS WITH A TOTAL THROUGHPUT OF 360 MBPS. THE HARDWARE INCLUDES THE HARDWARE SUPPORTS TRUE HDMI LOCAL OUTPUT VIA DVI-D/DVI-I PORTS, I5 PROCESSOR, DUAL NETWORK CARD AND SCHEDULED AUTO REBOOT FOR HARDWARE PERFORMANCE. THE NVR SUPPORTS CROSS PLATFORM CONNECTIVITY FOR WINDOWS AND MAC CLIENT SOFTWARE, ALLOWING YOU TO MONITOR AND CONNECT TO YOUR SYSTEM FROM ANYWHERE.		1	\$2,781.78
16-PORT GIGABIT POE+ NETWORK SWITCH 120WATTS POWER		1	\$286.28
MEGAPIX 2.1MP ULTRA-LOW-PROFILE IR OUTDOOR DOME CAMERA, 2.8MM FIXED LENS	\$325.15	13	\$4,226.90
WALL MOUNT BRACKET FOR EXTERIOR CAMERAS	\$43.24	13	\$562.18
MEGAPIX 2.1MP ULTRA-LOW-PROFILE IR INDOOR DOME CAMERA, 2.8MM FIXED LENS		1	\$273.46
SINGLE RECORDING LICENSE	\$106.03	14	\$1,484.42
CAT6E 23-4P UNS SOL CMR RISER PURPLE 1K	\$212.06	7	\$1,484.42
MISC MATERIAL		1	\$636.18
LABOR FOR INSTALLATION		1 LOT	\$5,998.25
		PARTS	\$11,735.62
		LABOR	\$5,998.25
		TAXES	\$715.87
		SHIPPING	
		TOTAL	\$18,449.74

Quote pricing is valid for 30-Days from date on quote.

CREDIT CARD PAYMENTS WILL INCUR A 3.5% PROCESSING FEE ADDED TO TOTAL CONTRACT

TERMS & CONDITIONS:

ACCEPTANCE OF THIS SALES QUOTE IS SUBJECT TO AGREEMENT BY CUSTOMER TO THE FOLLOWING CONDITIONS:

- WORK IS TO BE PERFORMED DURING NORMAL WORKING HOURS, M-F / 7-5.
- ONLY EQUIPMENT LISTED ABOVE SHALL BE INSTALLED AND WARRANTED BY PRE-VENTRONICS.
- PAINTING, PATCHING ARE EXCLUDED.
- 110 VOLT POWER TO BE PROVIDED BY OTHERS.
- PROPOSAL INCLUDES EQUIPMENT AS LISTED BASED ON DESIGN INFORMATION AVAILABLE AT TIME OF PROPOSAL. ADDITIONAL EQUIPMENT AND DESIGN CHANGES WILL BE QUOTED AND BILLED AS CHANGE ORDERS.
- STANDARD WARRANTY - PRE-VENTRONICS PROVIDES A 1 YEAR WARRANTY ON PARTS AND 90-DAYS ON LABOR FOR THE INSTALLATION OF THE ABOVE SYSTEM. WARRANTY SERVICES ARE PROVIDED DURING NORMAL BUSINESS HOURS, MONDAY THROUGH FRIDAY, 7:00 AM TO 5:00 PM (EXCLUDING HOLIDAYS). EMERGENCY RESPONSE DURING PREMIUM HOURS AND HOLIDAYS WILL BE CHARGED AT THE PREVAILING SERVICE RATES.
- ALL INVOICES ARE DUE AND PAYABLE TO PRE-VENTRONICS UPON RECEIPT.
- THE CUSTOMER AGREES TO HOLD HARMLESS AND INDEMNIFY PRE-VENTRONICS FROM ANY LOSS, DAMAGE AND/OR LITIGATION EXPENSE ARISING FROM ANY CLAIM OF INFRINGEMENT OF ANY PATENT, BY THE USE OR MANUFACTURE BY ANY ARTICLE FURNISHED TO IT BY THE SELLER UNDER THIS ORDER.

- MATERIALS NOT EXPLICITLY LISTED HEREIN ARE "BY OTHER" AND ARE EXCLUDED FROM THIS SCOPE OF WORK. NO ASSUMPTIONS SHOULD BE MADE REGARDING WHAT MATERIALS WILL BE PROVIDED, OTHER THAN WHAT IS LISTED IN THE ABOVE DESCRIPTION.

EXCEPTIONS:

- ACTS OF GOD AND OR TERRORISM ARE BEYOND OUR CONTROL AND PRE-VENTRONICS IS NOT RESPONSIBLE FOR THESE ACTS OR AS TO THE IMPACT THAT THEY MAY HAVE ON THIS SCOPE OF SERVICES OR DELIVERED PRICING.
- EXTRA LABOR COSTS IF INSTALLATION NEEDS TO TAKE PLACE AFTER NORMAL BUSINESS HOURS, WEEKENDS, OR HOLIDAYS.
- EXTRA COSTS FOR EXPEDITING OF PRODUCTS AND INSTALLATION.
- WARRANTY OF COMPONENTS NOT SUPPLIED BY PRE-VENTRONICS. REPAIRS AND/OR REPLACEMENTS WILL BE DONE ON A TIME AND MATERIALS BASIS UPON APPROVAL OF THE WORK.
- EXTRA COSTS FOR MATERIALS AND LABOR NOT INCLUDED IN THE ABOVE SCOPE OF SERVICES.
- EXTRA COSTS FOR INSURANCE REQUIREMENTS THAT EXCEED PRE-VENTRONICS STANDARD PROVISIONS OF 2M OR WAIVER OF SUBROGATION.
- CONDITION AND INTEGRITY OF EXISTING SITE.

WE APPRECIATE THE OPPORTUNITY TO PROVIDE OUR PROPOSAL FOR YOUR CONSIDERATION ON THIS PROJECT. PRE-VENTRONICS STRIVES TO BE A LEADER IN THE MARKET BY USING ONLY THE BEST AND LATEST PRODUCT ACCOMPANIED WITH HIGHLY QUALIFIED AND TRAINED TECHNICIANS FOR INSTALLATION AND SERVICE. YOU WILL DISCOVER THIS FIRSTHAND WHEN YOU CHOOSE US TO ASSIST YOU IN THIS PROJECT.



Spence Bledsoe, Project Manager

TEL:
sbledsoe@preventronics.com

CUSTOMER SIGNATURE DATE

PO NUMBER AMOUNT

Pre-venTronics

a division of Circuit-Tron Corporation
 ROC 093244 CR67

PRE-VENTRONICS
 1635 S. ALVERNON WAY
 TUCSON, AZ 85711
 TEL: (520) 790-4960
 FAX: (520) 790-7816

SALES QUOTE
 DATE 2/15/2023
**QUOTE#903087 - 36-
 GVR CAMERA
 SYSTEM-MEMBER
 SERVICES-SEND
 VIDEO TO WEST
 CENTER CAMERA
 SERVER REV-2**

SHIP TO	BILL TO
GVR - MAIN OFFICE 1070 S. CALLE DE LAS CASITAS GREEN VALLEY, AZ 85614	GREEN VALLEY RECREATION ASSOC.

PROJECT
GVR CAMERA SYSTEM-MEMBER SERVICES-SEND VIDEO TO WEST CENTER CAMERA SERVER REV-2

DESCRIPTION	UNIT PRICE	QTY	LINE TOTAL
GVR CAMERA SYSTEM-MEMBER SERVICES-SEND VIDEO TO WEST CENTER CAMERA SERVER REV-2			
2 PARKING LOT CAMERAS-4 EXTERIOR CAMERAS			
8-PORT GIGABIT POE+ NETWORK SWITCH 65WATTS POWER		1	\$136.31
MEGAPIX 2.1MP ULTRA-LOW-PROFILE IR OUTDOOR DOME CAMERA, 2.8MM FIXED LENS	\$325.15	6	\$1,950.88
WALL MOUNT BRACKET FOR EXTERIOR CAMERAS	\$43.25	6	\$259.47
SINGLE RECORDING LICENSE	\$106.03	6	\$636.18
CAT6E 23-4P UNS SOL CMR RISER PURPLE 1K	\$212.06	2	\$424.11
MISC MATERIAL		1	\$181.76
LABOR FOR INSTALLATION		1 LOT	\$1,999.41
		PARTS	\$3,588.72
		LABOR	\$1,999.41
		TAXES	\$218.91
		SHIPPING	
		TOTAL	\$5,807.03

Quote pricing is valid for 30-Days from date on quote.

CREDIT CARD PAYMENTS WILL INCUR A 3.5% PROCESSING FEE ADDED TO TOTAL CONTRACT

TERMS & CONDITIONS:

ACCEPTANCE OF THIS SALES QUOTE IS SUBJECT TO AGREEMENT BY CUSTOMER TO THE FOLLOWING CONDITIONS:

- WORK IS TO BE PERFORMED DURING NORMAL WORKING HOURS, M-F / 7-5.
- ONLY EQUIPMENT LISTED ABOVE SHALL BE INSTALLED AND WARRANTED BY PRE-VENTRONICS.
- PAINTING, PATCHING ARE EXCLUDED.
- 110 VOLT POWER TO BE PROVIDED BY OTHERS.
- PROPOSAL INCLUDES EQUIPMENT AS LISTED BASED ON DESIGN INFORMATION AVAILABLE AT TIME OF PROPOSAL. ADDITIONAL EQUIPMENT AND DESIGN CHANGES WILL BE QUOTED AND BILLED AS CHANGE ORDERS.
- STANDARD WARRANTY - PRE-VENTRONICS PROVIDES A 1 YEAR WARRANTY ON PARTS AND 90-DAYS ON LABOR FOR THE INSTALLATION OF THE ABOVE SYSTEM. WARRANTY SERVICES ARE PROVIDED DURING NORMAL BUSINESS HOURS, MONDAY THROUGH FRIDAY, 7:00 AM TO 5:00 PM (EXCLUDING HOLIDAYS). EMERGENCY RESPONSE DURING PREMIUM HOURS AND HOLIDAYS WILL BE CHARGED AT THE PREVAILING SERVICE RATES.
- ALL INVOICES ARE DUE AND PAYABLE TO PRE-VENTRONICS UPON RECEIPT.
- THE CUSTOMER AGREES TO HOLD HARMLESS AND INDEMNIFY PRE-VENTRONICS FROM ANY LOSS, DAMAGE AND/OR LITIGATION EXPENSE ARISING FROM ANY CLAIM OF INFRINGEMENT OF ANY PATENT, BY THE USE OR MANUFACTURE BY ANY ARTICLE FURNISHED TO IT BY THE SELLER UNDER THIS ORDER.
- MATERIALS NOT EXPLICITLY LISTED HEREIN ARE "BY OTHER" AND ARE EXCLUDED FROM THIS SCOPE OF WORK. NO ASSUMPTIONS SHOULD BE MADE REGARDING WHAT MATERIALS WILL BE PROVIDED, OTHER THAN WHAT IS LISTED IN THE ABOVE DESCRIPTION.

EXCEPTIONS:

- ACTS OF GOD AND OR TERRORISM ARE BEYOND OUR CONTROL AND PRE-VENTRONICS IS NOT RESPONSIBLE FOR THESE ACTS OR AS TO THE IMPACT THAT THEY MAY HAVE ON THIS SCOPE OF SERVICES OR DELIVERED PRICING.
- EXTRA LABOR COSTS IF INSTALLATION NEEDS TO TAKE PLACE AFTER NORMAL BUSINESS HOURS, WEEKENDS, OR HOLIDAYS.
- EXTRA COSTS FOR EXPEDITING OF PRODUCTS AND INSTALLATION.
- WARRANTY OF COMPONENTS NOT SUPPLIED BY PRE-VENTRONICS. REPAIRS AND/OR REPLACEMENTS WILL BE DONE ON A TIME AND MATERIALS BASIS UPON APPROVAL OF THE WORK.
- EXTRA COSTS FOR MATERIALS AND LABOR NOT INCLUDED IN THE ABOVE SCOPE OF SERVICES.
- EXTRA COSTS FOR INSURANCE REQUIREMENTS THAT EXCEED PRE-VENTRONICS STANDARD PROVISIONS OF 2M OR WAIVER OF SUBROGATION.
- CONDITION AND INTEGRITY OF EXISTING SITE.

WE APPRECIATE THE OPPORTUNITY TO PROVIDE OUR PROPOSAL FOR YOUR CONSIDERATION ON THIS PROJECT. PRE-VENTRONICS STRIVES TO BE A LEADER IN THE MARKET BY USING ONLY THE BEST AND LATEST PRODUCT ACCOMPANIED WITH HIGHLY QUALIFIED AND TRAINED TECHNICIANS FOR INSTALLATION AND SERVICE. YOU WILL DISCOVER THIS FIRSTHAND WHEN YOU CHOOSE US TO ASSIST YOU IN THIS PROJECT.



Spence Bledsoe, Project Manager

TEL:
 sbledsoe@preventronics.com

CUSTOMER SIGNATURE DATE

PO NUMBER AMOUNT

Pre-venTronics

a division of Circuit-Tron Corporation
ROC 093244 CR67

PRE-VENTRONICS
1635 S. ALVERNON WAY
TUCSON, AZ 85711
TEL: (520) 790-4960
FAX: (520) 790-7816

SALES QUOTE
DATE 2/15/2023
QUOTE#903087 - 37-
GVR CAMERA
SYSTEM-MADERA
VISTA REV-2

SHIP TO	BILL TO
GVR - MAIN OFFICE 1070 S. CALLE DE LAS CASITAS GREEN VALLEY, AZ 85614	GREEN VALLEY RECREATION ASSOC.

PROJECT
GVR CAMERA SYSTEM-MADERA VISTA GOING BACK TO SEVER AT ANOTHER SITE REV-2

DESCRIPTION	UNIT PRICE	QTY	LINE TOTAL
GVR CAMERA SYSTEM-MADERA VISTA GOING BACK TO SEVER AT ANOTHER SITE REV-2			
2 PARKING LOT CAMERA-3 EXTERIOR CAMERAS			
5-PORT GIGABIT POE+ NETWORK SWITCH 32WATTS POWER		1	\$99.97
MEGAPIX 2.1MP ULTRA-LOW-PROFILE IR OUTDOOR DOME CAMERA, 2.8MM FIXED LENS	\$325.15	5	\$1,625.73
WALL MOUNT BRACKET FOR EXTERIOR CAMERAS	\$43.25	5	\$216.23
SINGLE RECORDING LICENSE	\$106.03	5	\$530.15
CAT6E 23-4P UNS SOL CMR RISER PURPLE 1K		1	\$212.06
MISC MATERIAL		1	\$75.74
LABOR FOR INSTALLATION		1 LOT	\$1,832.79
		PARTS	\$2,759.87
		LABOR	\$1,832.79
		TAXES	\$168.35
		SHIPPING	
		TOTAL	\$4,761.02

Quote pricing is valid for 30-Days from date on quote.

CREDIT CARD PAYMENTS WILL INCUR A 3.5% PROCESSING FEE ADDED TO TOTAL CONTRACT

TERMS & CONDITIONS:

ACCEPTANCE OF THIS SALES QUOTE IS SUBJECT TO AGREEMENT BY CUSTOMER TO THE FOLLOWING CONDITIONS:

- WORK IS TO BE PERFORMED DURING NORMAL WORKING HOURS, M-F / 7-5.
- ONLY EQUIPMENT LISTED ABOVE SHALL BE INSTALLED AND WARRANTED BY PRE-VENTRONICS.
- PAINTING, PATCHING ARE EXCLUDED.
- 110 VOLT POWER TO BE PROVIDED BY OTHERS.
- PROPOSAL INCLUDES EQUIPMENT AS LISTED BASED ON DESIGN INFORMATION AVAILABLE AT TIME OF PROPOSAL. ADDITIONAL EQUIPMENT AND DESIGN CHANGES WILL BE QUOTED AND BILLED AS CHANGE ORDERS.
- STANDARD WARRANTY - PRE-VENTRONICS PROVIDES A 1 YEAR WARRANTY ON PARTS AND 90-DAYS ON LABOR FOR THE INSTALLATION OF THE ABOVE SYSTEM. WARRANTY SERVICES ARE PROVIDED DURING NORMAL BUSINESS HOURS, MONDAY THROUGH FRIDAY, 7:00 AM TO 5:00 PM (EXCLUDING HOLIDAYS). EMERGENCY RESPONSE DURING PREMIUM HOURS AND HOLIDAYS WILL BE CHARGED AT THE PREVAILING SERVICE RATES.
- ALL INVOICES ARE DUE AND PAYABLE TO PRE-VENTRONICS UPON RECEIPT.
- THE CUSTOMER AGREES TO HOLD HARMLESS AND INDEMNIFY PRE-VENTRONICS FROM ANY LOSS, DAMAGE AND/OR LITIGATION EXPENSE ARISING FROM ANY CLAIM OF INFRINGEMENT OF ANY PATENT, BY THE USE OR MANUFACTURE BY ANY ARTICLE FURNISHED TO IT BY THE SELLER UNDER THIS ORDER.
- MATERIALS NOT EXPLICITLY LISTED HEREIN ARE "BY OTHER" AND ARE EXCLUDED FROM THIS SCOPE OF WORK. NO ASSUMPTIONS SHOULD BE MADE REGARDING WHAT MATERIALS WILL BE PROVIDED, OTHER THAN WHAT IS LISTED IN THE ABOVE DESCRIPTION.

EXCEPTIONS:

- ACTS OF GOD AND OR TERRORISM ARE BEYOND OUR CONTROL AND PRE-VENTRONICS IS NOT RESPONSIBLE FOR THESE ACTS OR AS TO THE IMPACT THAT THEY MAY HAVE ON THIS SCOPE OF SERVICES OR DELIVERED PRICING.
- EXTRA LABOR COSTS IF INSTALLATION NEEDS TO TAKE PLACE AFTER NORMAL BUSINESS HOURS, WEEKENDS, OR HOLIDAYS.
- EXTRA COSTS FOR EXPEDITING OF PRODUCTS AND INSTALLATION.

- WARRANTY OF COMPONENTS NOT SUPPLIED BY PRE-VENTRONICS. REPAIRS AND/OR REPLACEMENTS WILL BE DONE ON A TIME AND MATERIALS BASIS UPON APPROVAL OF THE WORK.
- EXTRA COSTS FOR MATERIALS AND LABOR NOT INCLUDED IN THE ABOVE SCOPE OF SERVICES.
- EXTRA COSTS FOR INSURANCE REQUIREMENTS THAT EXCEED PRE-VENTRONICS STANDARD PROVISIONS OF 2M OR WAIVER OF SUBROGATION.
- CONDITION AND INTEGRITY OF EXISTING SITE.

WE APPRECIATE THE OPPORTUNITY TO PROVIDE OUR PROPOSAL FOR YOUR CONSIDERATION ON THIS PROJECT. PRE-VENTRONICS STRIVES TO BE A LEADER IN THE MARKET BY USING ONLY THE BEST AND LATEST PRODUCT ACCOMPANIED WITH HIGHLY QUALIFIED AND TRAINED TECHNICIANS FOR INSTALLATION AND SERVICE. YOU WILL DISCOVER THIS FIRSTHAND WHEN YOU CHOOSE US TO ASSIST YOU IN THIS PROJECT.



Spence Bledsoe, Project Manager

TEL:
sbledsoe@preventronics.com

CUSTOMER SIGNATURE DATE

PO NUMBER AMOUNT

Pre-venTronics

a division of Circuit-Tron Corporation
 ROC 093244 CR67

PRE-VENTRONICS
 1635 S. ALVERNON WAY
 TUCSON, AZ 85711
 TEL: (520) 790-4960
 FAX: (520) 790-7816

SALES QUOTE
 DATE 2/15/2023
QUOTE#903087 - 38-
GVR CAMERA
SYSTEM- LAS
CAMPANAS SOCIAL
CENTER REV-2

SHIP TO	BILL TO
GVR - MAIN OFFICE 1070 S. CALLE DE LAS CASITAS GREEN VALLEY, AZ 85614	GREEN VALLEY RECREATION ASSOC.

PROJECT
GVR CAMERA SYSTEM- LAS CAMPANAS SOCIAL CENTER REV-2

DESCRIPTION	UNIT PRICE	QTY	LINE TOTAL
GVR CAMERA SYSTEM- LAS CAMPANAS SOCIAL CENTER REV-2			
4 PARKING LOT CAMERAS-3 EXTERIOR CAMERAS-6 INTERIOR CAMERAS			
64 CHANNEL, NVR WITH 6TB HDD. THE NVR RECORDS AND MANAGES UP TO 64 IP CAMERAS WITH A TOTAL THROUGHPUT OF 360 MBPS. THE HARDWARE INCLUDES THE HARDWARE SUPPORTS TRUE HDMI LOCAL OUTPUT VIA DVI-D/DVI-I PORTS, I5 PROCESSOR, DUAL NETWORK CARD AND SCHEDULED AUTO REBOOT FOR HARDWARE PERFORMANCE. THE NVR SUPPORTS CROSS PLATFORM CONNECTIVITY FOR WINDOWS AND MAC CLIENT SOFTWARE, ALLOWING YOU TO MONITOR AND CONNECT TO YOUR SYSTEM FROM ANYWHERE.		1	\$2,781.78
16-PORT GIGABIT POE+ NETWORK SWITCH 120WATTS POWER		1	\$286.28
MEGAPIX 2.1MP ULTRA-LOW-PROFILE IR OUTDOOR DOME CAMERA, 2.8MM FIXED LENS	\$325.15	7	\$2,276.03
WALL MOUNT BRACKET FOR EXTERIOR CAMERAS	\$43.25	3	\$129.74
MEGAPIX 2.1MP ULTRA-LOW-PROFILE IR INDOOR DOME CAMERA, 2.8MM FIXED LENS	\$273.47	6	\$1,640.79
SINGLE RECORDING LICENSE	\$106.03	13	\$1,378.39
CAT6E 23-4P UNS SOL CMR RISER PURPLE 1K	\$212.06	3	\$636.18
MISC MATERIAL		1	\$454.42
LABOR FOR INSTALLATION		1 LOT	\$4,831.92
		PARTS	\$9,583.60
		LABOR	\$4,831.92
		TAXES	\$584.60
		SHIPPING	
		TOTAL	\$15,000.12

Quote pricing is valid for 30-Days from date on quote.

CREDIT CARD PAYMENTS WILL INCUR A 3.5% PROCESSING FEE ADDED TO TOTAL CONTRACT

TERMS & CONDITIONS:

ACCEPTANCE OF THIS SALES QUOTE IS SUBJECT TO AGREEMENT BY CUSTOMER TO THE FOLLOWING CONDITIONS:

- WORK IS TO BE PERFORMED DURING NORMAL WORKING HOURS, M-F / 7-5.
- ONLY EQUIPMENT LISTED ABOVE SHALL BE INSTALLED AND WARRANTED BY PRE-VENTRONICS.
- PAINTING, PATCHING ARE EXCLUDED.
- 110 VOLT POWER TO BE PROVIDED BY OTHERS.
- PROPOSAL INCLUDES EQUIPMENT AS LISTED BASED ON DESIGN INFORMATION AVAILABLE AT TIME OF PROPOSAL. ADDITIONAL EQUIPMENT AND DESIGN CHANGES WILL BE QUOTED AND BILLED AS CHANGE ORDERS.
- STANDARD WARRANTY - PRE-VENTRONICS PROVIDES A 1 YEAR WARRANTY ON PARTS AND 90-DAYS ON LABOR FOR THE INSTALLATION OF THE ABOVE SYSTEM. WARRANTY SERVICES ARE PROVIDED DURING NORMAL BUSINESS HOURS, MONDAY THROUGH FRIDAY, 7:00 AM TO 5:00 PM (EXCLUDING HOLIDAYS). EMERGENCY RESPONSE DURING PREMIUM HOURS AND HOLIDAYS WILL BE CHARGED AT THE PREVAILING SERVICE RATES.
- ALL INVOICES ARE DUE AND PAYABLE TO PRE-VENTRONICS UPON RECEIPT.
- THE CUSTOMER AGREES TO HOLD HARMLESS AND INDEMNIFY PRE-VENTRONICS FROM ANY LOSS, DAMAGE AND/OR LITIGATION EXPENSE ARISING FROM ANY CLAIM OF INFRINGEMENT OF ANY PATENT, BY THE USE OR MANUFACTURE BY ANY ARTICLE FURNISHED TO IT BY THE SELLER UNDER THIS ORDER.

- MATERIALS NOT EXPLICITLY LISTED HEREIN ARE "BY OTHER" AND ARE EXCLUDED FROM THIS SCOPE OF WORK. NO ASSUMPTIONS SHOULD BE MADE REGARDING WHAT MATERIALS WILL BE PROVIDED, OTHER THAN WHAT IS LISTED IN THE ABOVE DESCRIPTION.

EXCEPTIONS:

- ACTS OF GOD AND OR TERRORISM ARE BEYOND OUR CONTROL AND PRE-VENTRONICS IS NOT RESPONSIBLE FOR THESE ACTS OR AS TO THE IMPACT THAT THEY MAY HAVE ON THIS SCOPE OF SERVICES OR DELIVERED PRICING.
- EXTRA LABOR COSTS IF INSTALLATION NEEDS TO TAKE PLACE AFTER NORMAL BUSINESS HOURS, WEEKENDS, OR HOLIDAYS.
- EXTRA COSTS FOR EXPEDITING OF PRODUCTS AND INSTALLATION.
- WARRANTY OF COMPONENTS NOT SUPPLIED BY PRE-VENTRONICS. REPAIRS AND/OR REPLACEMENTS WILL BE DONE ON A TIME AND MATERIALS BASIS UPON APPROVAL OF THE WORK.
- EXTRA COSTS FOR MATERIALS AND LABOR NOT INCLUDED IN THE ABOVE SCOPE OF SERVICES.
- EXTRA COSTS FOR INSURANCE REQUIREMENTS THAT EXCEED PRE-VENTRONICS STANDARD PROVISIONS OF 2M OR WAIVER OF SUBROGATION.
- CONDITION AND INTEGRITY OF EXISTING SITE.

WE APPRECIATE THE OPPORTUNITY TO PROVIDE OUR PROPOSAL FOR YOUR CONSIDERATION ON THIS PROJECT. PRE-VENTRONICS STRIVES TO BE A LEADER IN THE MARKET BY USING ONLY THE BEST AND LATEST PRODUCT ACCOMPANIED WITH HIGHLY QUALIFIED AND TRAINED TECHNICIANS FOR INSTALLATION AND SERVICE. YOU WILL DISCOVER THIS FIRSTHAND WHEN YOU CHOOSE US TO ASSIST YOU IN THIS PROJECT.



Spence Bledsoe, Project Manager

TEL:
sbledsoe@preventronics.com

CUSTOMER SIGNATURE DATE

PO NUMBER AMOUNT

Pre-venTronics

a division of Circuit-Tron Corporation
ROC 093244 CR67

PRE-VENTRONICS
1635 S. ALVERNON WAY
TUCSON, AZ 85711
TEL: (520) 790-4960
FAX: (520) 790-7816

SALES QUOTE
DATE 2/15/2023
**QUOTE#903087 - 39-
GVR CAMERA
SYSTEM- DESERT
HILLS SOCIAL
CENTER REV-2**

SHIP TO	BILL TO
GVR - MAIN OFFICE 1070 S. CALLE DE LAS CASITAS GREEN VALLEY, AZ 85614	GREEN VALLEY RECREATION ASSOC.

PROJECT
GVR CAMERA SYSTEM- DESERT HILLS SOCIAL CENTER REV-2

DESCRIPTION	UNIT PRICE	QTY	LINE TOTAL
GVR CAMERA SYSTEM- DESERT HILLS SOCIAL CENTER REV-2			
4 PARKING LOT CAMERAS-7 EXTERIOR CAMERAS			
64 CHANNEL, NVR WITH 6TB HDD. THE NVR RECORDS AND MANAGES UP TO 64 IP CAMERAS WITH A TOTAL THROUGHPUT OF 360 MBPS. THE HARDWARE INCLUDES THE HARDWARE SUPPORTS TRUE HDMI LOCAL OUTPUT VIA DVI-D/DVI-I PORTS, I5 PROCESSOR, DUAL NETWORK CARD AND SCHEDULED AUTO REBOOT FOR HARDWARE PERFORMANCE. THE NVR SUPPORTS CROSS PLATFORM CONNECTIVITY FOR WINDOWS AND MAC CLIENT SOFTWARE, ALLOWING YOU TO MONITOR AND CONNECT TO YOUR SYSTEM FROM ANYWHERE.		1	\$2,781.78
16-PORT GIGABIT POE+ NETWORK SWITCH 120WATTS POWER		1	\$286.28
MEGAPIX 2.1MP ULTRA-LOW-PROFILE IR OUTDOOR DOME CAMERA, 2.8MM FIXED LENS	\$325.15	11	\$3,576.61
WALL MOUNT BRACKET FOR EXTERIOR CAMERAS	\$43.25	10	\$432.45
SINGLE RECORDING LICENSE	\$106.03	11	\$1,166.32
CAT6E 23-4P UNS SOL CMR RISER PURPLE 1K	\$212.06	6	\$1,272.35
MISC MATERIAL		1	\$454.42
LABOR FOR INSTALLATION, ENGINEERING AND PROJECT MANAGEMENT		1 LOT	\$4,998.54
		PARTS	\$9,970.20
		LABOR	\$4,998.54
		TAXES	\$608.18
		SHIPPING	
		TOTAL	\$15,576.93

Quote pricing is valid for 30-Days from date on quote.

CREDIT CARD PAYMENTS WILL INCUR A 3.5% PROCESSING FEE ADDED TO TOTAL CONTRACT

TERMS & CONDITIONS:

ACCEPTANCE OF THIS SALES QUOTE IS SUBJECT TO AGREEMENT BY CUSTOMER TO THE FOLLOWING CONDITIONS:

- WORK IS TO BE PERFORMED DURING NORMAL WORKING HOURS, M-F / 7-5.
- ONLY EQUIPMENT LISTED ABOVE SHALL BE INSTALLED AND WARRANTED BY PRE-VENTRONICS.
- PAINTING, PATCHING ARE EXCLUDED.
- 110 VOLT POWER TO BE PROVIDED BY OTHERS.
- PROPOSAL INCLUDES EQUIPMENT AS LISTED BASED ON DESIGN INFORMATION AVAILABLE AT TIME OF PROPOSAL. ADDITIONAL EQUIPMENT AND DESIGN CHANGES WILL BE QUOTED AND BILLED AS CHANGE ORDERS.
- STANDARD WARRANTY - PRE-VENTRONICS PROVIDES A 1 YEAR WARRANTY ON PARTS AND 90-DAYS ON LABOR FOR THE INSTALLATION OF THE ABOVE SYSTEM. WARRANTY SERVICES ARE PROVIDED DURING NORMAL BUSINESS HOURS, MONDAY THROUGH FRIDAY, 7:00 AM TO 5:00 PM (EXCLUDING HOLIDAYS). EMERGENCY RESPONSE DURING PREMIUM HOURS AND HOLIDAYS WILL BE CHARGED AT THE PREVAILING SERVICE RATES.
- ALL INVOICES ARE DUE AND PAYABLE TO PRE-VENTRONICS UPON RECEIPT.
- THE CUSTOMER AGREES TO HOLD HARMLESS AND INDEMNIFY PRE-VENTRONICS FROM ANY LOSS, DAMAGE AND/OR LITIGATION EXPENSE ARISING FROM ANY CLAIM OF INFRINGEMENT OF ANY PATENT, BY THE USE OR MANUFACTURE BY ANY ARTICLE FURNISHED TO IT BY THE SELLER UNDER THIS ORDER.

- MATERIALS NOT EXPLICITLY LISTED HEREIN ARE "BY OTHER" AND ARE EXCLUDED FROM THIS SCOPE OF WORK. NO ASSUMPTIONS SHOULD BE MADE REGARDING WHAT MATERIALS WILL BE PROVIDED, OTHER THAN WHAT IS LISTED IN THE ABOVE DESCRIPTION.

EXCEPTIONS:

- ACTS OF GOD AND OR TERRORISM ARE BEYOND OUR CONTROL AND PRE-VENTRONICS IS NOT RESPONSIBLE FOR THESE ACTS OR AS TO THE IMPACT THAT THEY MAY HAVE ON THIS SCOPE OF SERVICES OR DELIVERED PRICING.
- EXTRA LABOR COSTS IF INSTALLATION NEEDS TO TAKE PLACE AFTER NORMAL BUSINESS HOURS, WEEKENDS, OR HOLIDAYS.
- EXTRA COSTS FOR EXPEDITING OF PRODUCTS AND INSTALLATION.
- WARRANTY OF COMPONENTS NOT SUPPLIED BY PRE-VENTRONICS. REPAIRS AND/OR REPLACEMENTS WILL BE DONE ON A TIME AND MATERIALS BASIS UPON APPROVAL OF THE WORK.
- EXTRA COSTS FOR MATERIALS AND LABOR NOT INCLUDED IN THE ABOVE SCOPE OF SERVICES.
- EXTRA COSTS FOR INSURANCE REQUIREMENTS THAT EXCEED PRE-VENTRONICS STANDARD PROVISIONS OF 2M OR WAIVER OF SUBROGATION.
- CONDITION AND INTEGRITY OF EXISTING SITE.

WE APPRECIATE THE OPPORTUNITY TO PROVIDE OUR PROPOSAL FOR YOUR CONSIDERATION ON THIS PROJECT. PRE-VENTRONICS STRIVES TO BE A LEADER IN THE MARKET BY USING ONLY THE BEST AND LATEST PRODUCT ACCOMPANIED WITH HIGHLY QUALIFIED AND TRAINED TECHNICIANS FOR INSTALLATION AND SERVICE. YOU WILL DISCOVER THIS FIRSTHAND WHEN YOU CHOOSE US TO ASSIST YOU IN THIS PROJECT.



Spence Bledsoe, Project Manager

TEL:
sbledsoe@preventronics.com

CUSTOMER SIGNATURE

DATE

PO NUMBER

AMOUNT

Pre-venTronics

a division of Circuit-Tron Corporation
 ROC 093244 CR67

PRE-VENTRONICS
 1635 S. ALVERNON WAY
 TUCSON, AZ 85711
 TEL: (520) 790-4960
 FAX: (520) 790-7816

SALES QUOTE
 DATE 2/15/2023
**QUOTE#903087 - 40-
 GVR CAMERA
 SYSTEM- EAST
 SOCIAL CENTER-
 SEND VIDEO TO
 DESERT HILLS REV-2**

SHIP TO	BILL TO
GVR - MAIN OFFICE 1070 S. CALLE DE LAS CASITAS GREEN VALLEY, AZ 85614	GREEN VALLEY RECREATION ASSOC.

PROJECT
GVR CAMERA SYSTEM- EAST SOCIAL CENTER- SEND VIDEO TO DESERT HILLS CAMERA SERVER REV-2

DESCRIPTION	UNIT PRICE	QTY	LINE TOTAL
GVR CAMERA SYSTEM- EAST SOCIAL CENTER- SEND VIDEO TO DESERT HILLS CAMERA SERVER REV-2			
4 PARKING LOT CAMERAS- 6 EXTERIOR CAMERAS		1	
16-PORT GIGABIT POE+ NETWORK SWITCH 120WATTS POWER		1	\$286.28
MEGAPIX 2.1MP ULTRA-LOW-PROFILE IR OUTDOOR DOME CAMERA, 2.8MM FIXED LENS	\$325.15	10	\$3,251.46
WALL MOUNT BRACKET FOR EXTERIOR CAMERAS	\$43.25	10	\$432.45
SINGLE RECORDING LICENSE	\$106.03	10	\$1,060.29
CAT6E 23-4P UNS SOL CMR RISER PURPLE 1K	\$212.06	3	\$636.18
MISC MATERIAL		1	\$181.76
LABOR FOR INSTALLATION		1 LOT	\$2,415.96
		PARTS	\$5,848.42
		LABOR	\$2,415.96
		TAXES	\$356.75
		SHIPPING	
		TOTAL	\$8,621.13

Quote pricing is valid for 30-Days from date on quote.

CREDIT CARD PAYMENTS WILL INCUR A 3.5% PROCESSING FEE ADDED TO TOTAL CONTRACT

TERMS & CONDITIONS:

ACCEPTANCE OF THIS SALES QUOTE IS SUBJECT TO AGREEMENT BY CUSTOMER TO THE FOLLOWING CONDITIONS:

- WORK IS TO BE PERFORMED DURING NORMAL WORKING HOURS, M-F / 7-5.
- ONLY EQUIPMENT LISTED ABOVE SHALL BE INSTALLED AND WARRANTED BY PRE-VENTRONICS.
- PAINTING, PATCHING ARE EXCLUDED.
- 110 VOLT POWER TO BE PROVIDED BY OTHERS.
- PROPOSAL INCLUDES EQUIPMENT AS LISTED BASED ON DESIGN INFORMATION AVAILABLE AT TIME OF PROPOSAL. ADDITIONAL EQUIPMENT AND DESIGN CHANGES WILL BE QUOTED AND BILLED AS CHANGE ORDERS.
- STANDARD WARRANTY - PRE-VENTRONICS PROVIDES A 1 YEAR WARRANTY ON PARTS AND 90-DAYS ON LABOR FOR THE INSTALLATION OF THE ABOVE SYSTEM. WARRANTY SERVICES ARE PROVIDED DURING NORMAL BUSINESS HOURS, MONDAY THROUGH FRIDAY, 7:00 AM TO 5:00 PM (EXCLUDING HOLIDAYS). EMERGENCY RESPONSE DURING PREMIUM HOURS AND HOLIDAYS WILL BE CHARGED AT THE PREVAILING SERVICE RATES.
- ALL INVOICES ARE DUE AND PAYABLE TO PRE-VENTRONICS UPON RECEIPT.
- THE CUSTOMER AGREES TO HOLD HARMLESS AND INDEMNIFY PRE-VENTRONICS FROM ANY LOSS, DAMAGE AND/OR LITIGATION EXPENSE ARISING FROM ANY CLAIM OF INFRINGEMENT OF ANY PATENT, BY THE USE OR MANUFACTURE BY ANY ARTICLE FURNISHED TO IT BY THE SELLER UNDER THIS ORDER.
- MATERIALS NOT EXPLICITLY LISTED HEREIN ARE "BY OTHER" AND ARE EXCLUDED FROM THIS SCOPE OF WORK. NO ASSUMPTIONS SHOULD BE MADE REGARDING WHAT MATERIALS WILL BE PROVIDED, OTHER THAN WHAT IS LISTED IN THE ABOVE DESCRIPTION.

EXCEPTIONS:

- ACTS OF GOD AND OR TERRORISM ARE BEYOND OUR CONTROL AND PRE-VENTRONICS IS NOT RESPONSIBLE FOR THESE ACTS OR AS TO THE IMPACT THAT THEY MAY HAVE ON THIS SCOPE OF SERVICES OR DELIVERED PRICING.
- EXTRA LABOR COSTS IF INSTALLATION NEEDS TO TAKE PLACE AFTER NORMAL BUSINESS HOURS, WEEKENDS, OR HOLIDAYS.
- EXTRA COSTS FOR EXPEDITING OF PRODUCTS AND INSTALLATION.
- WARRANTY OF COMPONENTS NOT SUPPLIED BY PRE-VENTRONICS. REPAIRS AND/OR REPLACEMENTS WILL BE DONE ON A TIME AND MATERIALS BASIS UPON APPROVAL OF THE WORK.
- EXTRA COSTS FOR MATERIALS AND LABOR NOT INCLUDED IN THE ABOVE SCOPE OF SERVICES.
- EXTRA COSTS FOR INSURANCE REQUIREMENTS THAT EXCEED PRE-VENTRONICS STANDARD PROVISIONS OF 2M OR WAIVER OF SUBROGATION.
- CONDITION AND INTEGRITY OF EXISTING SITE.

WE APPRECIATE THE OPPORTUNITY TO PROVIDE OUR PROPOSAL FOR YOUR CONSIDERATION ON THIS PROJECT. PRE-VENTRONICS STRIVES TO BE A LEADER IN THE MARKET BY USING ONLY THE BEST AND LATEST PRODUCT ACCOMPANIED WITH HIGHLY QUALIFIED AND TRAINED TECHNICIANS FOR INSTALLATION AND SERVICE. YOU WILL DISCOVER THIS FIRSTHAND WHEN YOU CHOOSE US TO ASSIST YOU IN THIS PROJECT.



Spence Bledsoe, Project Manager

TEL:
sbledsoe@preventronics.com

CUSTOMER SIGNATURE DATE

PO NUMBER AMOUNT

Pre-venTronics

a division of Circuit-Tron Corporation
ROC 093244 CR67

PRE-VENTRONICS
1635 S. ALVERNON WAY
TUCSON, AZ 85711
TEL: (520) 790-4960
FAX: (520) 790-7816

SALES QUOTE

DATE 2/15/2023

**QUOTE#903087 - 41-
GVR CAMERA
SYSTEM-
CONTINENTAL VISTA
REV-2**

SHIP TO	BILL TO
GVR - MAIN OFFICE 1070 S. CALLE DE LAS CASITAS GREEN VALLEY, AZ 85614	GREEN VALLEY RECREATION ASSOC.

PROJECT
GVR CAMERA SYSTEM-CONTINENTAL VISTA-VIDEO SENT TO ANOTHER SITE REV-2

DESCRIPTION	UNIT PRICE	QTY	LINE TOTAL
GVR CAMERA SYSTEM-CONTINENTAL VISTA-VIDEO SENT TO ANOTHER SITE REV-2			
1 PARKING LOT CAMERA-2 EXTERIOR CAMERAS			
5-PORT GIGABIT POE+ NETWORK SWITCH 32WATTS POWER		1	\$99.97
MEGAPIX 2.1MP ULTRA-LOW-PROFILE IR OUTDOOR DOME CAMERA, 2.8MM FIXED LENS	\$325.15	3	\$975.44
WALL MOUNT BRACKET FOR EXTERIOR CAMERAS	\$43.25	3	\$129.74
SINGLE RECORDING LICENSE	\$106.03	3	\$318.08
CAT6E 23-4P UNS SOL CMR RISER PURPLE 1K	\$212.05	1.5	\$318.08
MISC MATERIAL		1	\$75.74
LABOR FOR INSTALLATION		1 LOT	\$1,666.17
		PARTS	\$1,917.06
		LABOR	\$1,666.17
		TAXES	\$116.94
		SHIPPING	
		TOTAL	\$3,700.17

Quote pricing is valid for 30-Days from date on quote.

CREDIT CARD PAYMENTS WILL INCUR A 3.5% PROCESSING FEE ADDED TO TOTAL CONTRACT

TERMS & CONDITIONS:

ACCEPTANCE OF THIS SALES QUOTE IS SUBJECT TO AGREEMENT BY CUSTOMER TO THE FOLLOWING CONDITIONS:

- WORK IS TO BE PERFORMED DURING NORMAL WORKING HOURS, M-F / 7-5.
- ONLY EQUIPMENT LISTED ABOVE SHALL BE INSTALLED AND WARRANTED BY PRE-VENTRONICS.
- PAINTING, PATCHING ARE EXCLUDED.
- 110 VOLT POWER TO BE PROVIDED BY OTHERS.
- PROPOSAL INCLUDES EQUIPMENT AS LISTED BASED ON DESIGN INFORMATION AVAILABLE AT TIME OF PROPOSAL. ADDITIONAL EQUIPMENT AND DESIGN CHANGES WILL BE QUOTED AND BILLED AS CHANGE ORDERS.
- STANDARD WARRANTY - PRE-VENTRONICS PROVIDES A 1 YEAR WARRANTY ON PARTS AND 90-DAYS ON LABOR FOR THE INSTALLATION OF THE ABOVE SYSTEM. WARRANTY SERVICES ARE PROVIDED DURING NORMAL BUSINESS HOURS, MONDAY THROUGH FRIDAY, 7:00 AM TO 5:00 PM (EXCLUDING HOLIDAYS). EMERGENCY RESPONSE DURING PREMIUM HOURS AND HOLIDAYS WILL BE CHARGED AT THE PREVAILING SERVICE RATES.
- ALL INVOICES ARE DUE AND PAYABLE TO PRE-VENTRONICS UPON RECEIPT.
- THE CUSTOMER AGREES TO HOLD HARMLESS AND INDEMNIFY PRE-VENTRONICS FROM ANY LOSS, DAMAGE AND/OR LITIGATION EXPENSE ARISING FROM ANY CLAIM OF INFRINGEMENT OF ANY PATENT, BY THE USE OR MANUFACTURE BY ANY ARTICLE FURNISHED TO IT BY THE SELLER UNDER THIS ORDER.
- MATERIALS NOT EXPLICITLY LISTED HEREIN ARE "BY OTHER" AND ARE EXCLUDED FROM THIS SCOPE OF WORK. NO ASSUMPTIONS SHOULD BE MADE REGARDING WHAT MATERIALS WILL BE PROVIDED, OTHER THAN WHAT IS LISTED IN THE ABOVE DESCRIPTION.

EXCEPTIONS:

- ACTS OF GOD AND OR TERRORISM ARE BEYOND OUR CONTROL AND PRE-VENTRONICS IS NOT RESPONSIBLE FOR THESE ACTS OR AS TO THE IMPACT THAT THEY MAY HAVE ON THIS SCOPE OF SERVICES OR DELIVERED PRICING.
- EXTRA LABOR COSTS IF INSTALLATION NEEDS TO TAKE PLACE AFTER NORMAL BUSINESS HOURS, WEEKENDS, OR HOLIDAYS.

- EXTRA COSTS FOR EXPEDITING OF PRODUCTS AND INSTALLATION.
- WARRANTY OF COMPONENTS NOT SUPPLIED BY PRE-VENTRONICS. REPAIRS AND/OR REPLACEMENTS WILL BE DONE ON A TIME AND MATERIALS BASIS UPON APPROVAL OF THE WORK.
- EXTRA COSTS FOR MATERIALS AND LABOR NOT INCLUDED IN THE ABOVE SCOPE OF SERVICES.
- EXTRA COSTS FOR INSURANCE REQUIREMENTS THAT EXCEED PRE-VENTRONICS STANDARD PROVISIONS OF 2M OR WAIVER OF SUBROGATION.
- CONDITION AND INTEGRITY OF EXISTING SITE.

WE APPRECIATE THE OPPORTUNITY TO PROVIDE OUR PROPOSAL FOR YOUR CONSIDERATION ON THIS PROJECT. PRE-VENTRONICS STRIVES TO BE A LEADER IN THE MARKET BY USING ONLY THE BEST AND LATEST PRODUCT ACCOMPANIED WITH HIGHLY QUALIFIED AND TRAINED TECHNICIANS FOR INSTALLATION AND SERVICE. YOU WILL DISCOVER THIS FIRSTHAND WHEN YOU CHOOSE US TO ASSIST YOU IN THIS PROJECT.

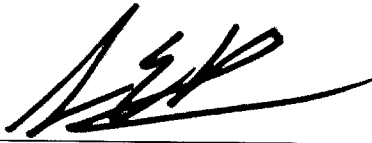

Spence Bledsoe, Project Manager

TEL:
 sbledsoe@preventronics.com

CUSTOMER SIGNATURE DATE

PO NUMBER AMOUNT

Pre-venTronics

a division of Circuit-Tron Corporation
 ROC 093244 CR67

PRE-VENTRONICS
 1635 S. ALVERNON WAY
 TUCSON, AZ 85711
 TEL: (520) 790-4960
 FAX: (520) 790-7816

SALES QUOTE
 DATE 2/15/2023
QUOTE#903087 - 42-
GVR CAMERA
SYSTEM-CASA
PALOMA I- REV-2

SHIP TO	BILL TO
GVR - MAIN OFFICE 1070 S. CALLE DE LAS CASITAS GREEN VALLEY, AZ 85614	GREEN VALLEY RECREATION ASSOC.

PROJECT
GVR CAMERA SYSTEM-CASA PALOMA I CAMERAS RECORDED AT ANOTER SITE- REV-2

DESCRIPTION	UNIT PRICE	QTY	LINE TOTAL
GVR CAMERA SYSTEM-CASA PALOMA I CAMERAS RECORDED AT ANOTER SITE- REV-2			
1 PARKING LOT CAMERA-2 EXTERIOR CAMERA			
5-PORT GIGABIT POE+ NETWORK SWITCH 32WATTS POWER		1	\$99.97
MEGAPIX 2.1MP ULTRA-LOW-PROFILE IR OUTDOOR DOME CAMERA, 2.8MM FIXED LENS	\$325.15	3	\$975.44
WALL MOUNT BRACKET FOR EXTERIOR CAMERAS	\$43.25	3	\$129.74
SINGLE RECORDING LICENSE	\$106.03	3	\$318.08
CAT6E 23-4P UNS SOL CMR RISER PURPLE 1K		1	\$212.06
MISC MATERIAL		1	\$106.03
LABOR FOR INSTALLATION		1 LOT	\$1,249.63
		PARTS	\$1,841.32
		LABOR	\$1,249.63
		TAXES	\$112.32
		SHIPPING	
		TOTAL	\$3,203.27

Quote pricing is valid for 30-Days from date on quote.

CREDIT CARD PAYMENTS WILL INCUR A 3.5% PROCESSING FEE ADDED TO TOTAL CONTRACT

TERMS & CONDITIONS:

ACCEPTANCE OF THIS SALES QUOTE IS SUBJECT TO AGREEMENT BY CUSTOMER TO THE FOLLOWING CONDITIONS:

- WORK IS TO BE PERFORMED DURING NORMAL WORKING HOURS, M-F / 7-5.
- ONLY EQUIPMENT LISTED ABOVE SHALL BE INSTALLED AND WARRANTED BY PRE-VENTRONICS.
- PAINTING, PATCHING ARE EXCLUDED.
- 110 VOLT POWER TO BE PROVIDED BY OTHERS.
- PROPOSAL INCLUDES EQUIPMENT AS LISTED BASED ON DESIGN INFORMATION AVAILABLE AT TIME OF PROPOSAL. ADDITIONAL EQUIPMENT AND DESIGN CHANGES WILL BE QUOTED AND BILLED AS CHANGE ORDERS.
- STANDARD WARRANTY - PRE-VENTRONICS PROVIDES A 1 YEAR WARRANTY ON PARTS AND 90-DAYS ON LABOR FOR THE INSTALLATION OF THE ABOVE SYSTEM. WARRANTY SERVICES ARE PROVIDED DURING NORMAL BUSINESS HOURS, MONDAY THROUGH FRIDAY, 7:00 AM TO 5:00 PM (EXCLUDING HOLIDAYS). EMERGENCY RESPONSE DURING PREMIUM HOURS AND HOLIDAYS WILL BE CHARGED AT THE PREVAILING SERVICE RATES.
- ALL INVOICES ARE DUE AND PAYABLE TO PRE-VENTRONICS UPON RECEIPT.
- THE CUSTOMER AGREES TO HOLD HARMLESS AND INDEMNIFY PRE-VENTRONICS FROM ANY LOSS, DAMAGE AND/OR LITIGATION EXPENSE ARISING FROM ANY CLAIM OF INFRINGEMENT OF ANY PATENT, BY THE USE OR MANUFACTURE BY ANY ARTICLE FURNISHED TO IT BY THE SELLER UNDER THIS ORDER.
- MATERIALS NOT EXPLICITLY LISTED HEREIN ARE "BY OTHER" AND ARE EXCLUDED FROM THIS SCOPE OF WORK. NO ASSUMPTIONS SHOULD BE MADE REGARDING WHAT MATERIALS WILL BE PROVIDED, OTHER THAN WHAT IS LISTED IN THE ABOVE DESCRIPTION.

EXCEPTIONS:

- ACTS OF GOD AND OR TERRORISM ARE BEYOND OUR CONTROL AND PRE-VENTRONICS IS NOT RESPONSIBLE FOR THESE ACTS OR AS TO THE IMPACT THAT THEY MAY HAVE ON THIS SCOPE OF SERVICES OR DELIVERED PRICING.
- EXTRA LABOR COSTS IF INSTALLATION NEEDS TO TAKE PLACE AFTER NORMAL BUSINESS HOURS, WEEKENDS, OR HOLIDAYS.
- EXTRA COSTS FOR EXPEDITING OF PRODUCTS AND INSTALLATION.

- WARRANTY OF COMPONENTS NOT SUPPLIED BY PRE-VENTRONICS. REPAIRS AND/OR REPLACEMENTS WILL BE DONE ON A TIME AND MATERIALS BASIS UPON APPROVAL OF THE WORK.
- EXTRA COSTS FOR MATERIALS AND LABOR NOT INCLUDED IN THE ABOVE SCOPE OF SERVICES.
- EXTRA COSTS FOR INSURANCE REQUIREMENTS THAT EXCEED PRE-VENTRONICS STANDARD PROVISIONS OF 2M OR WAIVER OF SUBROGATION.
- CONDITION AND INTEGRITY OF EXISTING SITE.

WE APPRECIATE THE OPPORTUNITY TO PROVIDE OUR PROPOSAL FOR YOUR CONSIDERATION ON THIS PROJECT. PRE-VENTRONICS STRIVES TO BE A LEADER IN THE MARKET BY USING ONLY THE BEST AND LATEST PRODUCT ACCOMPANIED WITH HIGHLY QUALIFIED AND TRAINED TECHNICIANS FOR INSTALLATION AND SERVICE. YOU WILL DISCOVER THIS FIRSTHAND WHEN YOU CHOOSE US TO ASSIST YOU IN THIS PROJECT.



Spence Bledsoe, Project Manager

TEL:
 sbledsoe@preventronics.com

CUSTOMER SIGNATURE DATE

PO NUMBER AMOUNT

Pre-venTronics

a division of Circuit-Tron Corporation
ROC 093244 CR67

PRE-VENTRONICS
1635 S. ALVERNON WAY
TUCSON, AZ 85711
TEL: (520) 790-4960
FAX: (520) 790-7816

SALES QUOTE
DATE 2/15/2023
QUOTE#903087 - 43-
GVR CAMERA
SYSTEM- CANOA
RANCH RECREATION
CENTER-REV-2

SHIP TO	BILL TO
GVR - MAIN OFFICE 1070 S. CALLE DE LAS CASITAS GREEN VALLEY, AZ 85614	GREEN VALLEY RECREATION ASSOC.

PROJECT
GVR CAMERA SYSTEM- CANOA RANCH RECREATION CENTER-REV-2

DESCRIPTION	UNIT PRICE	QTY	LINE TOTAL
GVR CAMERA SYSTEM- CANOA RANCH RECREATION CENTER-REV-2			
2 PARKING LOT CAMERAS-3 EXTERIOR CAMERAS-2 INTERIOR CAMERAS			
64 CHANNEL, NVR WITH 6TB HDD. THE NVR RECORDS AND MANAGES UP TO 64 IP CAMERAS WITH A TOTAL THROUGHPUT OF 360 MBPS. THE HARDWARE INCLUDES THE HARDWARE SUPPORTS TRUE HDMI LOCAL OUTPUT VIA DVI-D/DVI-I PORTS, I5 PROCESSOR, DUAL NETWORK CARD AND SCHEDULED AUTO REBOOT FOR HARDWARE PERFORMANCE. THE NVR SUPPORTS CROSS PLATFORM CONNECTIVITY FOR WINDOWS AND MAC CLIENT SOFTWARE, ALLOWING YOU TO MONITOR AND CONNECT TO YOUR SYSTEM FROM ANYWHERE.		1	\$2,781.78
16-PORT GIGABIT POE+ NETWORK SWITCH 120WATTS POWER		1	\$286.28
MEGAPIX 2.1MP ULTRA-LOW-PROFILE IR OUTDOOR DOME CAMERA, 2.8MM FIXED LENS	\$325.15	5	\$1,625.73
WALL MOUNT BRACKET FOR EXTERIOR CAMERAS	\$43.25	3	\$129.74
MEGAPIX 2.1MP ULTRA-LOW-PROFILE IR INDOOR DOME CAMERA, 2.8MM FIXED LENS	\$273.47	2	\$546.93
SINGLE RECORDING LICENSE	\$106.03	7	\$742.21
CAT6E 23-4P UNS SOL CMR RISER PURPLE 1K	\$212.06	3	\$636.18
MISC MATERIAL		1	\$583.17
LABOR FOR INSTALLATION		1 LOT	\$4,665.29
		PARTS	\$7,332.01
		LABOR	\$4,665.29
		TAXES	\$447.25
		SHIPPING	
		TOTAL	\$12,444.56

Quote pricing is valid for 30-Days from date on quote.

CREDIT CARD PAYMENTS WILL INCUR A 3.5% PROCESSING FEE ADDED TO TOTAL CONTRACT

TERMS & CONDITIONS:

ACCEPTANCE OF THIS SALES QUOTE IS SUBJECT TO AGREEMENT BY CUSTOMER TO THE FOLLOWING CONDITIONS:

- WORK IS TO BE PERFORMED DURING NORMAL WORKING HOURS, M-F / 7-5.
- ONLY EQUIPMENT LISTED ABOVE SHALL BE INSTALLED AND WARRANTED BY PRE-VENTRONICS.
- PAINTING, PATCHING ARE EXCLUDED.
- 110 VOLT POWER TO BE PROVIDED BY OTHERS.
- PROPOSAL INCLUDES EQUIPMENT AS LISTED BASED ON DESIGN INFORMATION AVAILABLE AT TIME OF PROPOSAL. ADDITIONAL EQUIPMENT AND DESIGN CHANGES WILL BE QUOTED AND BILLED AS CHANGE ORDERS.
- STANDARD WARRANTY - PRE-VENTRONICS PROVIDES A 1 YEAR WARRANTY ON PARTS AND 90-DAYS ON LABOR FOR THE INSTALLATION OF THE ABOVE SYSTEM. WARRANTY SERVICES ARE PROVIDED DURING NORMAL BUSINESS HOURS, MONDAY THROUGH FRIDAY, 7:00 AM TO 5:00 PM (EXCLUDING HOLIDAYS). EMERGENCY RESPONSE DURING PREMIUM HOURS AND HOLIDAYS WILL BE CHARGED AT THE PREVAILING SERVICE RATES.
- ALL INVOICES ARE DUE AND PAYABLE TO PRE-VENTRONICS UPON RECEIPT.
- THE CUSTOMER AGREES TO HOLD HARMLESS AND INDEMNIFY PRE-VENTRONICS FROM ANY LOSS, DAMAGE AND/OR LITIGATION EXPENSE ARISING FROM ANY CLAIM OF INFRINGEMENT OF ANY PATENT, BY THE USE OR MANUFACTURE BY ANY ARTICLE FURNISHED TO IT BY THE SELLER UNDER THIS ORDER.

- MATERIALS NOT EXPLICITLY LISTED HEREIN ARE "BY OTHER" AND ARE EXCLUDED FROM THIS SCOPE OF WORK. NO ASSUMPTIONS SHOULD BE MADE REGARDING WHAT MATERIALS WILL BE PROVIDED, OTHER THAN WHAT IS LISTED IN THE ABOVE DESCRIPTION.

EXCEPTIONS:

- ACTS OF GOD AND OR TERRORISM ARE BEYOND OUR CONTROL AND PRE-VENTRONICS IS NOT RESPONSIBLE FOR THESE ACTS OR AS TO THE IMPACT THAT THEY MAY HAVE ON THIS SCOPE OF SERVICES OR DELIVERED PRICING.
- EXTRA LABOR COSTS IF INSTALLATION NEEDS TO TAKE PLACE AFTER NORMAL BUSINESS HOURS, WEEKENDS, OR HOLIDAYS.
- EXTRA COSTS FOR EXPEDITING OF PRODUCTS AND INSTALLATION.
- WARRANTY OF COMPONENTS NOT SUPPLIED BY PRE-VENTRONICS. REPAIRS AND/OR REPLACEMENTS WILL BE DONE ON A TIME AND MATERIALS BASIS UPON APPROVAL OF THE WORK.
- EXTRA COSTS FOR MATERIALS AND LABOR NOT INCLUDED IN THE ABOVE SCOPE OF SERVICES.
- EXTRA COSTS FOR INSURANCE REQUIREMENTS THAT EXCEED PRE-VENTRONICS STANDARD PROVISIONS OF 2M OR WAIVER OF SUBROGATION.
- CONDITION AND INTEGRITY OF EXISTING SITE.

WE APPRECIATE THE OPPORTUNITY TO PROVIDE OUR PROPOSAL FOR YOUR CONSIDERATION ON THIS PROJECT. PRE-VENTRONICS STRIVES TO BE A LEADER IN THE MARKET BY USING ONLY THE BEST AND LATEST PRODUCT ACCOMPANIED WITH HIGHLY QUALIFIED AND TRAINED TECHNICIANS FOR INSTALLATION AND SERVICE. YOU WILL DISCOVER THIS FIRSTHAND WHEN YOU CHOOSE US TO ASSIST YOU IN THIS PROJECT.



Spence Bledsoe, Project Manager

TEL:
 sbledsoe@preventronics.com

CUSTOMER SIGNATURE

DATE

PO NUMBER

AMOUNT

Pre-venTronics

a division of Circuit-Tron Corporation
ROC 093244 CR67

PRE-VENTRONICS
1635 S. ALVERNON WAY
TUCSON, AZ 85711
TEL: (520) 790-4960
FAX: (520) 790-7816

SALES QUOTE

DATE 2/15/2023

QUOTE#903087 - 44-

**GVR CAMERA
SYSTEM- CASA
PALOMA II- SEND
VIDEO TO CANOA
RANCH CAMERA
SERVER- REV-2**

SHIP TO	BILL TO
GVR - MAIN OFFICE 1070 S. CALLE DE LAS CASITAS GREEN VALLEY, AZ 85614	GREEN VALLEY RECREATION ASSOC.

PROJECT
GVR CAMERA SYSTEM- CASA PALOMA II- SEND VIDEO TO CANOA RANCH CAMERA SERVER- REV-2

DESCRIPTION	UNIT PRICE	QTY	LINE TOTAL
GVR CAMERA SYSTEM- CASA PALOMA II- SEND VIDEO TO CANOA RANCH CAMERA SERVER- REV-2			
1 PARKING LOT CAMERAS-1 INTERIOR CAMERAS - 2 EXTERIOR CAMERAS			
5-PORT GIGABIT POE+ NETWORK SWITCH 32WATTS POWER		1	\$99.97
MEGAPIX 2.1MP ULTRA-LOW-PROFILE IR OUTDOOR DOME CAMERA, 2.8MM FIXED LENS	\$325.15	3	\$975.44
WALL MOUNT BRACKET FOR EXTERIOR CAMERAS	\$43.25	3	\$129.74
MEGAPIX 2.1MP ULTRA-LOW-PROFILE IR INDOOR DOME CAMERA, 2.8MM FIXED LENS		1	\$273.46
SINGLE RECORDING LICENSE	\$106.03	4	\$424.11
CAT6E 23-4P UNS SOL CMR RISER PURPLE 1K	\$212.06	2	\$424.11
MISC MATERIAL		1	\$181.76
LABOR FOR INSTALLATION		1 LOT	\$2,499.26
		PARTS	\$2,508.61
		LABOR	\$2,499.26
		TAXES	\$153.02
		SHIPPING	
		TOTAL	\$5,160.90

Quote pricing is valid for 30-Days from date on quote.

CREDIT CARD PAYMENTS WILL INCUR A 3.5% PROCESSING FEE ADDED TO TOTAL CONTRACT

TERMS & CONDITIONS:

ACCEPTANCE OF THIS SALES QUOTE IS SUBJECT TO AGREEMENT BY CUSTOMER TO THE FOLLOWING CONDITIONS:

- WORK IS TO BE PERFORMED DURING NORMAL WORKING HOURS, M-F / 7-5.
- ONLY EQUIPMENT LISTED ABOVE SHALL BE INSTALLED AND WARRANTED BY PRE-VENTRONICS.
- PAINTING, PATCHING ARE EXCLUDED.
- 110 VOLT POWER TO BE PROVIDED BY OTHERS.
- PROPOSAL INCLUDES EQUIPMENT AS LISTED BASED ON DESIGN INFORMATION AVAILABLE AT TIME OF PROPOSAL. ADDITIONAL EQUIPMENT AND DESIGN CHANGES WILL BE QUOTED AND BILLED AS CHANGE ORDERS.
- STANDARD WARRANTY - PRE-VENTRONICS PROVIDES A 1 YEAR WARRANTY ON PARTS AND 90-DAYS ON LABOR FOR THE INSTALLATION OF THE ABOVE SYSTEM. WARRANTY SERVICES ARE PROVIDED DURING NORMAL BUSINESS HOURS, MONDAY THROUGH FRIDAY, 7:00 AM TO 5:00 PM (EXCLUDING HOLIDAYS). EMERGENCY RESPONSE DURING PREMIUM HOURS AND HOLIDAYS WILL BE CHARGED AT THE PREVAILING SERVICE RATES.
- ALL INVOICES ARE DUE AND PAYABLE TO PRE-VENTRONICS UPON RECEIPT.
- THE CUSTOMER AGREES TO HOLD HARMLESS AND INDEMNIFY PRE-VENTRONICS FROM ANY LOSS, DAMAGE AND/OR LITIGATION EXPENSE ARISING FROM ANY CLAIM OF INFRINGEMENT OF ANY PATENT, BY THE USE OR MANUFACTURE BY ANY ARTICLE FURNISHED TO IT BY THE SELLER UNDER THIS ORDER.
- MATERIALS NOT EXPLICITLY LISTED HEREIN ARE "BY OTHER" AND ARE EXCLUDED FROM THIS SCOPE OF WORK. NO ASSUMPTIONS SHOULD BE MADE REGARDING WHAT MATERIALS WILL BE PROVIDED, OTHER THAN WHAT IS LISTED IN THE ABOVE DESCRIPTION.

EXCEPTIONS:

- ACTS OF GOD AND OR TERRORISM ARE BEYOND OUR CONTROL AND PRE-VENTRONICS IS NOT RESPONSIBLE FOR THESE ACTS OR AS TO THE IMPACT THAT THEY MAY HAVE ON THIS SCOPE OF SERVICES OR DELIVERED PRICING.
- EXTRA LABOR COSTS IF INSTALLATION NEEDS TO TAKE PLACE AFTER NORMAL BUSINESS HOURS, WEEKENDS, OR HOLIDAYS.
- EXTRA COSTS FOR EXPEDITING OF PRODUCTS AND INSTALLATION.
- WARRANTY OF COMPONENTS NOT SUPPLIED BY PRE-VENTRONICS. REPAIRS AND/OR REPLACEMENTS WILL BE DONE ON A TIME AND MATERIALS BASIS UPON APPROVAL OF THE WORK.
- EXTRA COSTS FOR MATERIALS AND LABOR NOT INCLUDED IN THE ABOVE SCOPE OF SERVICES.
- EXTRA COSTS FOR INSURANCE REQUIREMENTS THAT EXCEED PRE-VENTRONICS STANDARD PROVISIONS OF 2M OR WAIVER OF SUBROGATION.
- CONDITION AND INTEGRITY OF EXISTING SITE.

WE APPRECIATE THE OPPORTUNITY TO PROVIDE OUR PROPOSAL FOR YOUR CONSIDERATION ON THIS PROJECT. PRE-VENTRONICS STRIVES TO BE A LEADER IN THE MARKET BY USING ONLY THE BEST AND LATEST PRODUCT ACCOMPANIED WITH HIGHLY QUALIFIED AND TRAINED TECHNICIANS FOR INSTALLATION AND SERVICE. YOU WILL DISCOVER THIS FIRSTHAND WHEN YOU CHOOSE US TO ASSIST YOU IN THIS PROJECT.



Spence Bledsoe, Project Manager

TEL:
sbledsoe@preventronics.com

CUSTOMER SIGNATURE

DATE

PO NUMBER

AMOUNT

Pre-venTronics

a division of Circuit-Tron Corporation
ROC 093244 CR67

PRE-VENTRONICS
1635 S. ALVERNON WAY
TUCSON, AZ 85711
TEL: (520) 790-4960
FAX: (520) 790-7816

SALES QUOTE
DATE 2/15/2023
**QUOTE#903087 - 45-
GVR CAMERA
SYSTEM- CANOA
HILLS RECREATION
CENTERS-REV-2**

SHIP TO	BILL TO
GVR - MAIN OFFICE 1070 S. CALLE DE LAS CASITAS GREEN VALLEY, AZ 85614	GREEN VALLEY RECREATION ASSOC.

PROJECT
GVR CAMERA SYSTEM- CANOA HILLS RECREATION CENTERS-REV-2

DESCRIPTION	UNIT PRICE	QTY	LINE TOTAL
GVR CAMERA SYSTEM- CANOA HILLS RECREATION CENTERS-REV-2			
3 PARKING LOT CAMERAS-3 EXTERIOR CAMERAS-2 INTERIOR CAMERAS			
64 CHANNEL, NVR WITH 6TB HDD. THE NVR RECORDS AND MANAGES UP TO 64 IP CAMERAS WITH A TOTAL THROUGHPUT OF 360 MBPS. THE HARDWARE INCLUDES THE HARDWARE SUPPORTS TRUE HDMI LOCAL OUTPUT VIA DVI-D/DVI-I PORTS, I5 PROCESSOR, DUAL NETWORK CARD AND SCHEDULED AUTO REBOOT FOR HARDWARE PERFORMANCE. THE NVR SUPPORTS CROSS PLATFORM CONNECTIVITY FOR WINDOWS AND MAC CLIENT SOFTWARE, ALLOWING YOU TO MONITOR AND CONNECT TO YOUR SYSTEM FROM ANYWHERE.		1	\$2,781.78
16-PORT GIGABIT POE+ NETWORK SWITCH 120WATTS POWER		1	\$286.28
MEGAPIX 2.1MP ULTRA-LOW-PROFILE IR OUTDOOR DOME CAMERA, 2.8MM FIXED LENS	\$325.15	6	\$1,950.88
WALL MOUNT BRACKET FOR EXTERIOR CAMERAS	\$43.25	6	\$259.47
MEGAPIX 2.1MP ULTRA-LOW-PROFILE IR INDOOR DOME CAMERA, 2.8MM FIXED LENS	\$273.47	2	\$546.93
SINGLE RECORDING LICENSE	\$106.03	8	\$848.24
CAT6E 23-4P UNS SOL CMR RISER PURPLE 1K	\$212.06	5	\$1,060.29
MISC MATERIAL		1	\$583.17
LABOR FOR INSTALLATION		1 LOT	\$4,998.54
		PARTS	\$8,317.03
		LABOR	\$4,998.54
		TAXES	\$507.34
		SHIPPING	
		TOTAL	\$13,822.91

Quote pricing is valid for 30-Days from date on quote.

CREDIT CARD PAYMENTS WILL INCUR A 3.5% PROCESSING FEE ADDED TO TOTAL CONTRACT

TERMS & CONDITIONS:

ACCEPTANCE OF THIS SALES QUOTE IS SUBJECT TO AGREEMENT BY CUSTOMER TO THE FOLLOWING CONDITIONS:

- WORK IS TO BE PERFORMED DURING NORMAL WORKING HOURS, M-F / 7-5.
- ONLY EQUIPMENT LISTED ABOVE SHALL BE INSTALLED AND WARRANTED BY PRE-VENTRONICS.
- PAINTING, PATCHING ARE EXCLUDED.
- 110 VOLT POWER TO BE PROVIDED BY OTHERS.
- PROPOSAL INCLUDES EQUIPMENT AS LISTED BASED ON DESIGN INFORMATION AVAILABLE AT TIME OF PROPOSAL. ADDITIONAL EQUIPMENT AND DESIGN CHANGES WILL BE QUOTED AND BILLED AS CHANGE ORDERS.
- STANDARD WARRANTY - PRE-VENTRONICS PROVIDES A 1 YEAR WARRANTY ON PARTS AND 90-DAYS ON LABOR FOR THE INSTALLATION OF THE ABOVE SYSTEM. WARRANTY SERVICES ARE PROVIDED DURING NORMAL BUSINESS HOURS, MONDAY THROUGH FRIDAY, 7:00 AM TO 5:00 PM (EXCLUDING HOLIDAYS). EMERGENCY RESPONSE DURING PREMIUM HOURS AND HOLIDAYS WILL BE CHARGED AT THE PREVAILING SERVICE RATES.
- ALL INVOICES ARE DUE AND PAYABLE TO PRE-VENTRONICS UPON RECEIPT.
- THE CUSTOMER AGREES TO HOLD HARMLESS AND INDEMNIFY PRE-VENTRONICS FROM ANY LOSS, DAMAGE AND/OR LITIGATION EXPENSE ARISING FROM ANY CLAIM OF INFRINGEMENT OF ANY PATENT, BY THE USE OR MANUFACTURE BY ANY ARTICLE FURNISHED TO IT BY THE SELLER UNDER THIS ORDER.

- MATERIALS NOT EXPLICITLY LISTED HEREIN ARE "BY OTHER" AND ARE EXCLUDED FROM THIS SCOPE OF WORK. NO ASSUMPTIONS SHOULD BE MADE REGARDING WHAT MATERIALS WILL BE PROVIDED, OTHER THAN WHAT IS LISTED IN THE ABOVE DESCRIPTION.

EXCEPTIONS:

- ACTS OF GOD AND OR TERRORISM ARE BEYOND OUR CONTROL AND PRE-VENTRONICS IS NOT RESPONSIBLE FOR THESE ACTS OR AS TO THE IMPACT THAT THEY MAY HAVE ON THIS SCOPE OF SERVICES OR DELIVERED PRICING.
- EXTRA LABOR COSTS IF INSTALLATION NEEDS TO TAKE PLACE AFTER NORMAL BUSINESS HOURS, WEEKENDS, OR HOLIDAYS.
- EXTRA COSTS FOR EXPEDITING OF PRODUCTS AND INSTALLATION.
- WARRANTY OF COMPONENTS NOT SUPPLIED BY PRE-VENTRONICS. REPAIRS AND/OR REPLACEMENTS WILL BE DONE ON A TIME AND MATERIALS BASIS UPON APPROVAL OF THE WORK.
- EXTRA COSTS FOR MATERIALS AND LABOR NOT INCLUDED IN THE ABOVE SCOPE OF SERVICES.
- EXTRA COSTS FOR INSURANCE REQUIREMENTS THAT EXCEED PRE-VENTRONICS STANDARD PROVISIONS OF 2M OR WAIVER OF SUBROGATION.
- CONDITION AND INTEGRITY OF EXISTING SITE.

WE APPRECIATE THE OPPORTUNITY TO PROVIDE OUR PROPOSAL FOR YOUR CONSIDERATION ON THIS PROJECT. PRE-VENTRONICS STRIVES TO BE A LEADER IN THE MARKET BY USING ONLY THE BEST AND LATEST PRODUCT ACCOMPANIED WITH HIGHLY QUALIFIED AND TRAINED TECHNICIANS FOR INSTALLATION AND SERVICE. YOU WILL DISCOVER THIS FIRSTHAND WHEN YOU CHOOSE US TO ASSIST YOU IN THIS PROJECT.



Spence Bledsoe, Project Manager

TEL:
sbledsoe@preventronics.com

CUSTOMER SIGNATURE DATE

PO NUMBER AMOUNT

Pre-venTronics

a division of Circuit-Tron Corporation
 ROC 093244 CR67

PRE-VENTRONICS
 1635 S. ALVERNON WAY
 TUCSON, AZ 85711
 TEL: (520) 790-4960
 FAX: (520) 790-7816

SALES QUOTE
 DATE 2/15/2023
**QUOTE#903087 - 46-
 GVR CAMERA
 SYSTEM- ABREGO
 SOUTH- SEND VIDEO
 TO CANOA HILLS
 CAMERA SERVER-
 REV-2**

SHIP TO	BILL TO
GVR - MAIN OFFICE 1070 S. CALLE DE LAS CASITAS GREEN VALLEY, AZ 85614	GREEN VALLEY RECREATION ASSOC.

PROJECT
GVR CAMERA SYSTEM- ABREGO SOUTH- SEND VIDEO TO CANOA HILLS CAMERA SERVER-REV-2

DESCRIPTION	UNIT PRICE	QTY	LINE TOTAL
GVR CAMERA SYSTEM- ABREGO SOUTH- SEND VIDEO TO CANOA HILLS CAMERA SERVER-REV-2			
2 PARKING LOT CAMERAS- 3 EXTERIOR CAMERAS			
16-PORT GIGABIT POE+ NETWORK SWITCH 120WATTS POWER		1	\$286.28
MEGAPIX 2.1MP ULTRA-LOW-PROFILE IR OUTDOOR DOME CAMERA, 2.8MM FIXED LENS	\$325.15	5	\$1,625.73
WALL MOUNT BRACKET FOR EXTERIOR CAMERAS	\$43.25	5	\$216.23
SINGLE RECORDING LICENSE	\$106.03	5	\$530.15
CAT6E 23-4P UNS SOL CMR RISER PURPLE 1K		1	\$212.06
MISC MATERIAL		1	\$181.76
LABOR FOR INSTALLATION		1 LOT	\$1,999.41
		PARTS	\$3,052.21
		LABOR	\$1,999.41
		TAXES	\$186.18
		SHIPPING	
		TOTAL	\$5,237.80

Quote pricing is valid for 30-Days from date on quote.

CREDIT CARD PAYMENTS WILL INCUR A 3.5% PROCESSING FEE ADDED TO TOTAL CONTRACT

TERMS & CONDITIONS:

ACCEPTANCE OF THIS SALES QUOTE IS SUBJECT TO AGREEMENT BY CUSTOMER TO THE FOLLOWING CONDITIONS:

- WORK IS TO BE PERFORMED DURING NORMAL WORKING HOURS, M-F / 7-5.
- ONLY EQUIPMENT LISTED ABOVE SHALL BE INSTALLED AND WARRANTED BY PRE-VENTRONICS.
- PAINTING, PATCHING ARE EXCLUDED.
- 110 VOLT POWER TO BE PROVIDED BY OTHERS.
- PROPOSAL INCLUDES EQUIPMENT AS LISTED BASED ON DESIGN INFORMATION AVAILABLE AT TIME OF PROPOSAL. ADDITIONAL EQUIPMENT AND DESIGN CHANGES WILL BE QUOTED AND BILLED AS CHANGE ORDERS.
- STANDARD WARRANTY - PRE-VENTRONICS PROVIDES A 1 YEAR WARRANTY ON PARTS AND 90-DAYS ON LABOR FOR THE INSTALLATION OF THE ABOVE SYSTEM. WARRANTY SERVICES ARE PROVIDED DURING NORMAL BUSINESS HOURS, MONDAY THROUGH FRIDAY, 7:00 AM TO 5:00 PM (EXCLUDING HOLIDAYS). EMERGENCY RESPONSE DURING PREMIUM HOURS AND HOLIDAYS WILL BE CHARGED AT THE PREVAILING SERVICE RATES.
- ALL INVOICES ARE DUE AND PAYABLE TO PRE-VENTRONICS UPON RECEIPT.
- THE CUSTOMER AGREES TO HOLD HARMLESS AND INDEMNIFY PRE-VENTRONICS FROM ANY LOSS, DAMAGE AND/OR LITIGATION EXPENSE ARISING FROM ANY CLAIM OF INFRINGEMENT OF ANY PATENT, BY THE USE OR MANUFACTURE BY ANY ARTICLE FURNISHED TO IT BY THE SELLER UNDER THIS ORDER.
- MATERIALS NOT EXPLICITLY LISTED HEREIN ARE "BY OTHER" AND ARE EXCLUDED FROM THIS SCOPE OF WORK. NO ASSUMPTIONS SHOULD BE MADE REGARDING WHAT MATERIALS WILL BE PROVIDED, OTHER THAN WHAT IS LISTED IN THE ABOVE DESCRIPTION.

EXCEPTIONS:

- ACTS OF GOD AND OR TERRORISM ARE BEYOND OUR CONTROL AND PRE-VENTRONICS IS NOT RESPONSIBLE FOR THESE ACTS OR AS TO THE IMPACT THAT THEY MAY HAVE ON THIS SCOPE OF SERVICES OR DELIVERED PRICING.
- EXTRA LABOR COSTS IF INSTALLATION NEEDS TO TAKE PLACE AFTER NORMAL BUSINESS HOURS, WEEKENDS, OR HOLIDAYS.
- EXTRA COSTS FOR EXPEDITING OF PRODUCTS AND INSTALLATION.
- WARRANTY OF COMPONENTS NOT SUPPLIED BY PRE-VENTRONICS. REPAIRS AND/OR REPLACEMENTS WILL BE DONE ON A TIME AND MATERIALS BASIS UPON APPROVAL OF THE WORK.
- EXTRA COSTS FOR MATERIALS AND LABOR NOT INCLUDED IN THE ABOVE SCOPE OF SERVICES.
- EXTRA COSTS FOR INSURANCE REQUIREMENTS THAT EXCEED PRE-VENTRONICS STANDARD PROVISIONS OF 2M OR WAIVER OF SUBROGATION.
- CONDITION AND INTEGRITY OF EXISTING SITE.

WE APPRECIATE THE OPPORTUNITY TO PROVIDE OUR PROPOSAL FOR YOUR CONSIDERATION ON THIS PROJECT. PRE-VENTRONICS STRIVES TO BE A LEADER IN THE MARKET BY USING ONLY THE BEST AND LATEST PRODUCT ACCOMPANIED WITH HIGHLY QUALIFIED AND TRAINED TECHNICIANS FOR INSTALLATION AND SERVICE. YOU WILL DISCOVER THIS FIRSTHAND WHEN YOU CHOOSE US TO ASSIST YOU IN THIS PROJECT.



Spence Bledsoe, Project Manager

TEL:
sbledsoe@preventronics.com

CUSTOMER SIGNATURE

DATE

PO NUMBER

AMOUNT

Pre-venTronics

a division of Circuit-Tron Corporation
ROC 093244 CR67

PRE-VENTRONICS
1635 S. ALVERNON WAY
TUCSON, AZ 85711
TEL: (520) 790-4960
FAX: (520) 790-7816

SALES QUOTE
DATE 2/15/2023
QUOTE#903087 - 47-
GVR CAMERA
SYSTEM- ABREGO
NORTH- SEND VIDEO
TO CANOA HILLS
CAMERA SERVER-
REV-2

SHIP TO	BILL TO
GVR - MAIN OFFICE 1070 S. CALLE DE LAS CASITAS GREEN VALLEY, AZ 85614	GREEN VALLEY RECREATION ASSOC.

PROJECT
GVR CAMERA SYSTEM- ABREGO NORTH- SEND VIDEO TO CANOA HILLS CAMERA SERVER-REV-2

DESCRIPTION	UNIT PRICE	QTY	LINE TOTAL
GVR CAMERA SYSTEM- ABREGO NORTH- SEND VIDEO TO CANOA HILLS CAMERA SERVER-REV-2			
1 PARKING LOT CAMERAS - 1 EXTERIOR CAMERA			
5-PORT GIGABIT POE+ NETWORK SWITCH 32WATTS POWER		1	\$99.97
MEGAPIX 2.1MP ULTRA-LOW-PROFILE IR OUTDOOR DOME CAMERA, 2.8MM FIXED LENS	\$325.15	2	\$650.29
WALL MOUNT BRACKET FOR EXTERIOR CAMERAS	\$43.25	2	\$86.49
SINGLE RECORDING LICENSE	\$106.03	2	\$212.06
CAT6E 23-4P UNS SOL CMR RISER PURPLE 1K		1	\$212.06
MISC MATERIAL		1	\$181.76
LABOR FOR INSTALLATION		1 LOT	\$1,582.86
		PARTS	\$1,442.63
		LABOR	\$1,582.86
		TAXES	\$88.00
		SHIPPING	
		TOTAL	\$3,113.49

Quote pricing is valid for 30-Days from date on quote.

CREDIT CARD PAYMENTS WILL INCUR A 3.5% PROCESSING FEE ADDED TO TOTAL CONTRACT

TERMS & CONDITIONS:

ACCEPTANCE OF THIS SALES QUOTE IS SUBJECT TO AGREEMENT BY CUSTOMER TO THE FOLLOWING CONDITIONS:

- WORK IS TO BE PERFORMED DURING NORMAL WORKING HOURS, M-F / 7-5.
- ONLY EQUIPMENT LISTED ABOVE SHALL BE INSTALLED AND WARRANTED BY PRE-VENTRONICS.
- PAINTING, PATCHING ARE EXCLUDED.
- 110 VOLT POWER TO BE PROVIDED BY OTHERS.
- PROPOSAL INCLUDES EQUIPMENT AS LISTED BASED ON DESIGN INFORMATION AVAILABLE AT TIME OF PROPOSAL. ADDITIONAL EQUIPMENT AND DESIGN CHANGES WILL BE QUOTED AND BILLED AS CHANGE ORDERS.
- STANDARD WARRANTY - PRE-VENTRONICS PROVIDES A 1 YEAR WARRANTY ON PARTS AND 90-DAYS ON LABOR FOR THE INSTALLATION OF THE ABOVE SYSTEM. WARRANTY SERVICES ARE PROVIDED DURING NORMAL BUSINESS HOURS, MONDAY THROUGH FRIDAY, 7:00 AM TO 5:00 PM (EXCLUDING HOLIDAYS). EMERGENCY RESPONSE DURING PREMIUM HOURS AND HOLIDAYS WILL BE CHARGED AT THE PREVAILING SERVICE RATES.
- ALL INVOICES ARE DUE AND PAYABLE TO PRE-VENTRONICS UPON RECEIPT.
- THE CUSTOMER AGREES TO HOLD HARMLESS AND INDEMNIFY PRE-VENTRONICS FROM ANY LOSS, DAMAGE AND/OR LITIGATION EXPENSE ARISING FROM ANY CLAIM OF INFRINGEMENT OF ANY PATENT, BY THE USE OR MANUFACTURE BY ANY ARTICLE FURNISHED TO IT BY THE SELLER UNDER THIS ORDER.
- MATERIALS NOT EXPLICITLY LISTED HEREIN ARE "BY OTHER" AND ARE EXCLUDED FROM THIS SCOPE OF WORK. NO ASSUMPTIONS SHOULD BE MADE REGARDING WHAT MATERIALS WILL BE PROVIDED, OTHER THAN WHAT IS LISTED IN THE ABOVE DESCRIPTION.

EXCEPTIONS:

- ACTS OF GOD AND OR TERRORISM ARE BEYOND OUR CONTROL AND PRE-VENTRONICS IS NOT RESPONSIBLE FOR THESE ACTS OR AS TO THE IMPACT THAT THEY MAY HAVE ON THIS SCOPE OF SERVICES OR DELIVERED PRICING.
- EXTRA LABOR COSTS IF INSTALLATION NEEDS TO TAKE PLACE AFTER NORMAL BUSINESS HOURS, WEEKENDS, OR HOLIDAYS.
- EXTRA COSTS FOR EXPEDITING OF PRODUCTS AND INSTALLATION.
- WARRANTY OF COMPONENTS NOT SUPPLIED BY PRE-VENTRONICS. REPAIRS AND/OR REPLACEMENTS WILL BE DONE ON A TIME AND MATERIALS BASIS UPON APPROVAL OF THE WORK.
- EXTRA COSTS FOR MATERIALS AND LABOR NOT INCLUDED IN THE ABOVE SCOPE OF SERVICES.
- EXTRA COSTS FOR INSURANCE REQUIREMENTS THAT EXCEED PRE-VENTRONICS STANDARD PROVISIONS OF 2M OR WAIVER OF SUBROGATION.
- CONDITION AND INTEGRITY OF EXISTING SITE.

WE APPRECIATE THE OPPORTUNITY TO PROVIDE OUR PROPOSAL FOR YOUR CONSIDERATION ON THIS PROJECT. PRE-VENTRONICS STRIVES TO BE A LEADER IN THE MARKET BY USING ONLY THE BEST AND LATEST PRODUCT ACCOMPANIED WITH HIGHLY QUALIFIED AND TRAINED TECHNICIANS FOR INSTALLATION AND SERVICE. YOU WILL DISCOVER THIS FIRSTHAND WHEN YOU CHOOSE US TO ASSIST YOU IN THIS PROJECT.



Spence Bledsoe, Project Manager

TEL:
 sbledsoe@preventronics.com

CUSTOMER SIGNATURE DATE

PO NUMBER AMOUNT

Pre-venTronics

a division of Circuit-Tron Corporation
ROC 093244 CR67

PRE-VENTRONICS
1635 S. ALVERNON WAY
TUCSON, AZ 85711
TEL: (520) 790-4960
FAX: (520) 790-7816

SALES QUOTE

DATE 2/15/2023

**QUOTE#903087 - 48-
GVR CAMERA
SYSTEM- FACILITIES
MAINTANCE
BUILDING-REV-1**

SHIP TO	BILL TO
GVR - MAIN OFFICE 1070 S. CALLE DE LAS CASITAS GREEN VALLEY, AZ 85614	GREEN VALLEY RECREATION ASSOC.

PROJECT
GVR CAMERA SYSTEM- FACILITIES MAINTANCE BUILDING-REV-1

DESCRIPTION	UNIT PRICE	QTY	LINE TOTAL
GVR CAMERA SYSTEM- FACILITIES MAINTANCE BUILDING-REV-1			
1 PARKING LOT CAMERAS - 3 EXTERIOR CAMERA			
5-PORT GIGABIT POE+ NETWORK SWITCH 32WATTS POWER		1	\$99.97
MEGAPIX 2.1MP ULTRA-LOW-PROFILE IR OUTDOOR DOME CAMERA, 2.8MM FIXED LENS	\$325.15	4	\$1,300.59
WALL MOUNT BRACKET FOR EXTERIOR CAMERAS	\$43.25	4	\$172.98
SINGLE RECORDING LICENSE	\$106.03	4	\$424.11
CAT6E 23-4P UNS SOL CMR RISER PURPLE 1K	\$212.06	2	\$424.11
MISC MATERIAL		1	\$181.76
LABOR FOR INSTALLATION		1 LOT	\$2,332.65
		PARTS	\$2,603.53
		LABOR	\$2,332.65
		TAXES	\$158.82
		SHIPPING	
		TOTAL	\$5,095.00

Quote pricing is valid for 30-Days from date on quote.

CREDIT CARD PAYMENTS WILL INCUR A 3.5% PROCESSING FEE ADDED TO TOTAL CONTRACT

TERMS & CONDITIONS:

ACCEPTANCE OF THIS SALES QUOTE IS SUBJECT TO AGREEMENT BY CUSTOMER TO THE FOLLOWING CONDITIONS:

- WORK IS TO BE PERFORMED DURING NORMAL WORKING HOURS, M-F / 7-5.
- ONLY EQUIPMENT LISTED ABOVE SHALL BE INSTALLED AND WARRANTED BY PRE-VENTRONICS.
- PAINTING, PATCHING ARE EXCLUDED.
- 110 VOLT POWER TO BE PROVIDED BY OTHERS.
- PROPOSAL INCLUDES EQUIPMENT AS LISTED BASED ON DESIGN INFORMATION AVAILABLE AT TIME OF PROPOSAL. ADDITIONAL EQUIPMENT AND DESIGN CHANGES WILL BE QUOTED AND BILLED AS CHANGE ORDERS.
- STANDARD WARRANTY - PRE-VENTRONICS PROVIDES A 1 YEAR WARRANTY ON PARTS AND 90-DAYS ON LABOR FOR THE INSTALLATION OF THE ABOVE SYSTEM. WARRANTY SERVICES ARE PROVIDED DURING NORMAL BUSINESS HOURS, MONDAY THROUGH FRIDAY, 7:00 AM TO 5:00 PM (EXCLUDING HOLIDAYS). EMERGENCY RESPONSE DURING PREMIUM HOURS AND HOLIDAYS WILL BE CHARGED AT THE PREVAILING SERVICE RATES.
- ALL INVOICES ARE DUE AND PAYABLE TO PRE-VENTRONICS UPON RECEIPT.
- THE CUSTOMER AGREES TO HOLD HARMLESS AND INDEMNIFY PRE-VENTRONICS FROM ANY LOSS, DAMAGE AND/OR LITIGATION EXPENSE ARISING FROM ANY CLAIM OF INFRINGEMENT OF ANY PATENT, BY THE USE OR MANUFACTURE BY ANY ARTICLE FURNISHED TO IT BY THE SELLER UNDER THIS ORDER.
- MATERIALS NOT EXPLICITLY LISTED HEREIN ARE "BY OTHER" AND ARE EXCLUDED FROM THIS SCOPE OF WORK. NO ASSUMPTIONS SHOULD BE MADE REGARDING WHAT MATERIALS WILL BE PROVIDED, OTHER THAN WHAT IS LISTED IN THE ABOVE DESCRIPTION.

EXCEPTIONS:

- ACTS OF GOD AND OR TERRORISM ARE BEYOND OUR CONTROL AND PRE-VENTRONICS IS NOT RESPONSIBLE FOR THESE ACTS OR AS TO THE IMPACT THAT THEY MAY HAVE ON THIS SCOPE OF SERVICES OR DELIVERED PRICING.
- EXTRA LABOR COSTS IF INSTALLATION NEEDS TO TAKE PLACE AFTER NORMAL BUSINESS HOURS, WEEKENDS, OR HOLIDAYS.

- EXTRA COSTS FOR EXPEDITING OF PRODUCTS AND INSTALLATION.
- WARRANTY OF COMPONENTS NOT SUPPLIED BY PRE-VENTRONICS. REPAIRS AND/OR REPLACEMENTS WILL BE DONE ON A TIME AND MATERIALS BASIS UPON APPROVAL OF THE WORK.
- EXTRA COSTS FOR MATERIALS AND LABOR NOT INCLUDED IN THE ABOVE SCOPE OF SERVICES.
- EXTRA COSTS FOR INSURANCE REQUIREMENTS THAT EXCEED PRE-VENTRONICS STANDARD PROVISIONS OF 2M OR WAIVER OF SUBROGATION.
- CONDITION AND INTEGRITY OF EXISTING SITE.

WE APPRECIATE THE OPPORTUNITY TO PROVIDE OUR PROPOSAL FOR YOUR CONSIDERATION ON THIS PROJECT. PRE-VENTRONICS STRIVES TO BE A LEADER IN THE MARKET BY USING ONLY THE BEST AND LATEST PRODUCT ACCOMPANIED WITH HIGHLY QUALIFIED AND TRAINED TECHNICIANS FOR INSTALLATION AND SERVICE. YOU WILL DISCOVER THIS FIRSTHAND WHEN YOU CHOOSE US TO ASSIST YOU IN THIS PROJECT.



Spence Bledsoe, Project Manager

TEL:
sbledsoe@preventronics.com

CUSTOMER SIGNATURE

DATE

PO NUMBER

AMOUNT

Pre-venTronics

a division of Circuit-Tron Corporation
ROC 093244 CR67

PRE-VENTRONICS
1635 S. ALVERNON WAY
TUCSON, AZ 85711
TEL: (520) 790-4960
FAX: (520) 790-7816

SALES QUOTE
DATE 2/15/2023
QUOTE#903087 - 49-
GVR CAMERA
SYSTEM- PICKELBALL
COURT-REV-1

SHIP TO	BILL TO
GVR - MAIN OFFICE 1070 S. CALLE DE LAS CASITAS GREEN VALLEY, AZ 85614	GREEN VALLEY RECREATION ASSOC.

PROJECT
GVR CAMERA SYSTEM- PICKELBALL COURT-REV-1

DESCRIPTION	UNIT PRICE	QTY	LINE TOTAL
GVR CAMERA SYSTEM- PICKELBALL COURT-REV-1			
1 PARKING LOT CAMERAS - 4 EXTERIOR CAMERA			
8-PORT GIGABIT POE+ NETWORK SWITCH 65WATTS POWER		1	\$136.31
MEGAPIX 2.1MP ULTRA-LOW-PROFILE IR OUTDOOR DOME CAMERA, 2.8MM FIXED LENS	\$325.15	5	\$1,625.73
WALL MOUNT BRACKET FOR EXTERIOR CAMERAS	\$43.25	5	\$216.23
SINGLE RECORDING LICENSE	\$106.03	5	\$530.15
CAT6E 23-4P UNS SOL CMR RISER PURPLE 1K	\$212.06	2	\$424.11
MISC MATERIAL		1	\$181.76
LABOR FOR INSTALLATION		1 LOT	\$2,665.89
		PARTS	\$3,114.30
		LABOR	\$2,665.89
		TAXES	\$189.97
		SHIPPING	
		TOTAL	\$5,970.16

Quote pricing is valid for 30-Days from date on quote.

CREDIT CARD PAYMENTS WILL INCUR A 3.5% PROCESSING FEE ADDED TO TOTAL CONTRACT

TERMS & CONDITIONS:

ACCEPTANCE OF THIS SALES QUOTE IS SUBJECT TO AGREEMENT BY CUSTOMER TO THE FOLLOWING CONDITIONS:

- WORK IS TO BE PERFORMED DURING NORMAL WORKING HOURS, M-F / 7-5.
- ONLY EQUIPMENT LISTED ABOVE SHALL BE INSTALLED AND WARRANTED BY PRE-VENTRONICS.
- PAINTING, PATCHING ARE EXCLUDED.
- 110 VOLT POWER TO BE PROVIDED BY OTHERS.
- PROPOSAL INCLUDES EQUIPMENT AS LISTED BASED ON DESIGN INFORMATION AVAILABLE AT TIME OF PROPOSAL. ADDITIONAL EQUIPMENT AND DESIGN CHANGES WILL BE QUOTED AND BILLED AS CHANGE ORDERS.
- STANDARD WARRANTY - PRE-VENTRONICS PROVIDES A 1 YEAR WARRANTY ON PARTS AND 90-DAYS ON LABOR FOR THE INSTALLATION OF THE ABOVE SYSTEM. WARRANTY SERVICES ARE PROVIDED DURING NORMAL BUSINESS HOURS, MONDAY THROUGH FRIDAY, 7:00 AM TO 5:00 PM (EXCLUDING HOLIDAYS). EMERGENCY RESPONSE DURING PREMIUM HOURS AND HOLIDAYS WILL BE CHARGED AT THE PREVAILING SERVICE RATES.
- ALL INVOICES ARE DUE AND PAYABLE TO PRE-VENTRONICS UPON RECEIPT.
- THE CUSTOMER AGREES TO HOLD HARMLESS AND INDEMNIFY PRE-VENTRONICS FROM ANY LOSS, DAMAGE AND/OR LITIGATION EXPENSE ARISING FROM ANY CLAIM OF INFRINGEMENT OF ANY PATENT, BY THE USE OR MANUFACTURE BY ANY ARTICLE FURNISHED TO IT BY THE SELLER UNDER THIS ORDER.
- MATERIALS NOT EXPLICITLY LISTED HEREIN ARE "BY OTHER" AND ARE EXCLUDED FROM THIS SCOPE OF WORK. NO ASSUMPTIONS SHOULD BE MADE REGARDING WHAT MATERIALS WILL BE PROVIDED, OTHER THAN WHAT IS LISTED IN THE ABOVE DESCRIPTION.

EXCEPTIONS:

- ACTS OF GOD AND OR TERRORISM ARE BEYOND OUR CONTROL AND PRE-VENTRONICS IS NOT RESPONSIBLE FOR THESE ACTS OR AS TO THE IMPACT THAT THEY MAY HAVE ON THIS SCOPE OF SERVICES OR DELIVERED PRICING.
- EXTRA LABOR COSTS IF INSTALLATION NEEDS TO TAKE PLACE AFTER NORMAL BUSINESS HOURS, WEEKENDS, OR HOLIDAYS.
- EXTRA COSTS FOR EXPEDITING OF PRODUCTS AND INSTALLATION.

- WARRANTY OF COMPONENTS NOT SUPPLIED BY PRE-VENTRONICS. REPAIRS AND/OR REPLACEMENTS WILL BE DONE ON A TIME AND MATERIALS BASIS UPON APPROVAL OF THE WORK.
- EXTRA COSTS FOR MATERIALS AND LABOR NOT INCLUDED IN THE ABOVE SCOPE OF SERVICES.
- EXTRA COSTS FOR INSURANCE REQUIREMENTS THAT EXCEED PRE-VENTRONICS STANDARD PROVISIONS OF 2M OR WAIVER OF SUBROGATION.
- CONDITION AND INTEGRITY OF EXISTING SITE.

WE APPRECIATE THE OPPORTUNITY TO PROVIDE OUR PROPOSAL FOR YOUR CONSIDERATION ON THIS PROJECT. PRE-VENTRONICS STRIVES TO BE A LEADER IN THE MARKET BY USING ONLY THE BEST AND LATEST PRODUCT ACCOMPANIED WITH HIGHLY QUALIFIED AND TRAINED TECHNICIANS FOR INSTALLATION AND SERVICE. YOU WILL DISCOVER THIS FIRSTHAND WHEN YOU CHOOSE US TO ASSIST YOU IN THIS PROJECT.



Spence Bledsoe, Project Manager

TEL:
 sbledsoe@preventronics.com

CUSTOMER SIGNATURE DATE

PO NUMBER AMOUNT

Pre-venTronics

a division of Circuit-Tron Corporation
ROC 093244 CR67

PRE-VENTRONICS
1635 S. ALVERNON WAY
TUCSON, AZ 85711
TEL: (520) 790-4960
FAX: (520) 790-7816

SALES QUOTE
DATE 2/15/2023
**QUOTE#903087 - 50-
GVR CAMERA
SYSTEM- WEST
CENTER POOL-REV-1**

SHIP TO	BILL TO
GVR - MAIN OFFICE 1070 S. CALLE DE LAS CASITAS GREEN VALLEY, AZ 85614	GREEN VALLEY RECREATION ASSOC.

PROJECT
GVR CAMERA SYSTEM- WEST CENTER POOL-REV-1

DESCRIPTION	UNIT PRICE	QTY	LINE TOTAL
GVR CAMERA SYSTEM- WEST CENTER POOL-REV-1			
4 EXTERIOR CAMERA			
8-PORT GIGABIT POE+ NETWORK SWITCH 65WATTS POWER		1	\$136.31
MEGAPIX 2.1MP ULTRA-LOW-PROFILE IR OUTDOOR DOME CAMERA, 2.8MM FIXED LENS	\$325.15	4	\$1,300.59
WALL MOUNT BRACKET FOR EXTERIOR CAMERAS	\$43.25	4	\$172.98
SINGLE RECORDING LICENSE	\$106.03	4	\$424.11
CAT6E 23-4P UNS SOL CMR RISER PURPLE 1K	\$212.06	2	\$424.11
MISC MATERIAL		1	\$181.76
LABOR FOR INSTALLATION		1 LOT	\$2,332.65
		PARTS	\$2,639.87
		LABOR	\$2,332.65
		TAXES	\$161.03
		SHIPPING	
		TOTAL	\$5,133.55

Quote pricing is valid for 30-Days from date on quote.

CREDIT CARD PAYMENTS WILL INCUR A 3.5% PROCESSING FEE ADDED TO TOTAL CONTRACT

TERMS & CONDITIONS:

ACCEPTANCE OF THIS SALES QUOTE IS SUBJECT TO AGREEMENT BY CUSTOMER TO THE FOLLOWING CONDITIONS:

- WORK IS TO BE PERFORMED DURING NORMAL WORKING HOURS, M-F / 7-5.
- ONLY EQUIPMENT LISTED ABOVE SHALL BE INSTALLED AND WARRANTED BY PRE-VENTRONICS.
- PAINTING, PATCHING ARE EXCLUDED.
- 110 VOLT POWER TO BE PROVIDED BY OTHERS.
- PROPOSAL INCLUDES EQUIPMENT AS LISTED BASED ON DESIGN INFORMATION AVAILABLE AT TIME OF PROPOSAL. ADDITIONAL EQUIPMENT AND DESIGN CHANGES WILL BE QUOTED AND BILLED AS CHANGE ORDERS.
- STANDARD WARRANTY - PRE-VENTRONICS PROVIDES A 1 YEAR WARRANTY ON PARTS AND 90-DAYS ON LABOR FOR THE INSTALLATION OF THE ABOVE SYSTEM. WARRANTY SERVICES ARE PROVIDED DURING NORMAL BUSINESS HOURS, MONDAY THROUGH FRIDAY, 7:00 AM TO 5:00 PM (EXCLUDING HOLIDAYS). EMERGENCY RESPONSE DURING PREMIUM HOURS AND HOLIDAYS WILL BE CHARGED AT THE PREVAILING SERVICE RATES.
- ALL INVOICES ARE DUE AND PAYABLE TO PRE-VENTRONICS UPON RECEIPT.
- THE CUSTOMER AGREES TO HOLD HARMLESS AND INDEMNIFY PRE-VENTRONICS FROM ANY LOSS, DAMAGE AND/OR LITIGATION EXPENSE ARISING FROM ANY CLAIM OF INFRINGEMENT OF ANY PATENT, BY THE USE OR MANUFACTURE BY ANY ARTICLE FURNISHED TO IT BY THE SELLER UNDER THIS ORDER.
- MATERIALS NOT EXPLICITLY LISTED HEREIN ARE "BY OTHER" AND ARE EXCLUDED FROM THIS SCOPE OF WORK. NO ASSUMPTIONS SHOULD BE MADE REGARDING WHAT MATERIALS WILL BE PROVIDED, OTHER THAN WHAT IS LISTED IN THE ABOVE DESCRIPTION.

EXCEPTIONS:

- ACTS OF GOD AND OR TERRORISM ARE BEYOND OUR CONTROL AND PRE-VENTRONICS IS NOT RESPONSIBLE FOR THESE ACTS OR AS TO THE IMPACT THAT THEY MAY HAVE ON THIS SCOPE OF SERVICES OR DELIVERED PRICING.
- EXTRA LABOR COSTS IF INSTALLATION NEEDS TO TAKE PLACE AFTER NORMAL BUSINESS HOURS, WEEKENDS, OR HOLIDAYS.
- EXTRA COSTS FOR EXPEDITING OF PRODUCTS AND INSTALLATION.

- WARRANTY OF COMPONENTS NOT SUPPLIED BY PRE-VENTRONICS. REPAIRS AND/OR REPLACEMENTS WILL BE DONE ON A TIME AND MATERIALS BASIS UPON APPROVAL OF THE WORK.
- EXTRA COSTS FOR MATERIALS AND LABOR NOT INCLUDED IN THE ABOVE SCOPE OF SERVICES.
- EXTRA COSTS FOR INSURANCE REQUIREMENTS THAT EXCEED PRE-VENTRONICS STANDARD PROVISIONS OF 2M OR WAIVER OF SUBROGATION.
- CONDITION AND INTEGRITY OF EXISTING SITE.

WE APPRECIATE THE OPPORTUNITY TO PROVIDE OUR PROPOSAL FOR YOUR CONSIDERATION ON THIS PROJECT. PRE-VENTRONICS STRIVES TO BE A LEADER IN THE MARKET BY USING ONLY THE BEST AND LATEST PRODUCT ACCOMPANIED WITH HIGHLY QUALIFIED AND TRAINED TECHNICIANS FOR INSTALLATION AND SERVICE. YOU WILL DISCOVER THIS FIRSTHAND WHEN YOU CHOOSE US TO ASSIST YOU IN THIS PROJECT.



Spence Bledsoe, Project Manager

TEL:
 sbledsoe@preventronics.com

CUSTOMER SIGNATURE DATE

PO NUMBER AMOUNT

Pre-venTronics

a division of Circuit-Tron Corporation
ROC 093244 CR67

PRE-VENTRONICS
1635 S. ALVERNON WAY
TUCSON, AZ 85711
TEL: (520) 790-4960
FAX: (520) 790-7816

SALES QUOTE
DATE 2/15/2023
QUOTE#903087 - 51-
GVR CAMERA
SYSTEM- NEW
BUILDING-REV-1

SHIP TO	BILL TO
GVR - MAIN OFFICE 1070 S. CALLE DE LAS CASITAS GREEN VALLEY, AZ 85614	GREEN VALLEY RECREATION ASSOC.

PROJECT
GVR CAMERA SYSTEM- NEW BUILDING-REV-1

DESCRIPTION	UNIT PRICE	QTY	LINE TOTAL
GVR CAMERA SYSTEM- NEW BUILDING-REV-1			
3 PARKING LOT CAMERAS - 2 EXTERIOR CAMERA			
8-PORT GIGABIT POE+ NETWORK SWITCH 65WATTS POWER		1	\$136.31
MEGAPIX 2.1MP ULTRA-LOW-PROFILE IR OUTDOOR DOME CAMERA, 2.8MM FIXED LENS	\$325.15	5	\$1,625.73
WALL MOUNT BRACKET FOR EXTERIOR CAMERAS	\$43.25	5	\$216.23
SINGLE RECORDING LICENSE	\$106.03	5	\$530.15
CAT6E 23-4P UNS SOL CMR RISER PURPLE 1K	\$212.06	2	\$424.11
MISC MATERIAL		1	\$181.76
LABOR FOR INSTALLATION		1 LOT	\$2,332.65
		PARTS	\$3,114.30
		LABOR	\$2,332.65
		TAXES	\$189.97
		SHIPPING	
		TOTAL	\$5,636.92

Quote pricing is valid for 30-Days from date on quote.

CREDIT CARD PAYMENTS WILL INCUR A 3.5% PROCESSING FEE ADDED TO TOTAL CONTRACT

TERMS & CONDITIONS:

ACCEPTANCE OF THIS SALES QUOTE IS SUBJECT TO AGREEMENT BY CUSTOMER TO THE FOLLOWING CONDITIONS:

- WORK IS TO BE PERFORMED DURING NORMAL WORKING HOURS, M-F / 7-5.
- ONLY EQUIPMENT LISTED ABOVE SHALL BE INSTALLED AND WARRANTED BY PRE-VENTRONICS.
- PAINTING, PATCHING ARE EXCLUDED.
- 110 VOLT POWER TO BE PROVIDED BY OTHERS.
- PROPOSAL INCLUDES EQUIPMENT AS LISTED BASED ON DESIGN INFORMATION AVAILABLE AT TIME OF PROPOSAL. ADDITIONAL EQUIPMENT AND DESIGN CHANGES WILL BE QUOTED AND BILLED AS CHANGE ORDERS.
- STANDARD WARRANTY - PRE-VENTRONICS PROVIDES A 1 YEAR WARRANTY ON PARTS AND 90-DAYS ON LABOR FOR THE INSTALLATION OF THE ABOVE SYSTEM. WARRANTY SERVICES ARE PROVIDED DURING NORMAL BUSINESS HOURS, MONDAY THROUGH FRIDAY, 7:00 AM TO 5:00 PM (EXCLUDING HOLIDAYS). EMERGENCY RESPONSE DURING PREMIUM HOURS AND HOLIDAYS WILL BE CHARGED AT THE PREVAILING SERVICE RATES.
- ALL INVOICES ARE DUE AND PAYABLE TO PRE-VENTRONICS UPON RECEIPT.
- THE CUSTOMER AGREES TO HOLD HARMLESS AND INDEMNIFY PRE-VENTRONICS FROM ANY LOSS, DAMAGE AND/OR LITIGATION EXPENSE ARISING FROM ANY CLAIM OF INFRINGEMENT OF ANY PATENT, BY THE USE OR MANUFACTURE BY ANY ARTICLE FURNISHED TO IT BY THE SELLER UNDER THIS ORDER.
- MATERIALS NOT EXPLICITLY LISTED HEREIN ARE "BY OTHER" AND ARE EXCLUDED FROM THIS SCOPE OF WORK. NO ASSUMPTIONS SHOULD BE MADE REGARDING WHAT MATERIALS WILL BE PROVIDED, OTHER THAN WHAT IS LISTED IN THE ABOVE DESCRIPTION.

EXCEPTIONS:

- ACTS OF GOD AND OR TERRORISM ARE BEYOND OUR CONTROL AND PRE-VENTRONICS IS NOT RESPONSIBLE FOR THESE ACTS OR AS TO THE IMPACT THAT THEY MAY HAVE ON THIS SCOPE OF SERVICES OR DELIVERED PRICING.
- EXTRA LABOR COSTS IF INSTALLATION NEEDS TO TAKE PLACE AFTER NORMAL BUSINESS HOURS, WEEKENDS, OR HOLIDAYS.
- EXTRA COSTS FOR EXPEDITING OF PRODUCTS AND INSTALLATION.

- WARRANTY OF COMPONENTS NOT SUPPLIED BY PRE-VENTRONICS. REPAIRS AND/OR REPLACEMENTS WILL BE DONE ON A TIME AND MATERIALS BASIS UPON APPROVAL OF THE WORK.
- EXTRA COSTS FOR MATERIALS AND LABOR NOT INCLUDED IN THE ABOVE SCOPE OF SERVICES.
- EXTRA COSTS FOR INSURANCE REQUIREMENTS THAT EXCEED PRE-VENTRONICS STANDARD PROVISIONS OF 2M OR WAIVER OF SUBROGATION.
- CONDITION AND INTEGRITY OF EXISTING SITE.

WE APPRECIATE THE OPPORTUNITY TO PROVIDE OUR PROPOSAL FOR YOUR CONSIDERATION ON THIS PROJECT. PRE-VENTRONICS STRIVES TO BE A LEADER IN THE MARKET BY USING ONLY THE BEST AND LATEST PRODUCT ACCOMPANIED WITH HIGHLY QUALIFIED AND TRAINED TECHNICIANS FOR INSTALLATION AND SERVICE. YOU WILL DISCOVER THIS FIRSTHAND WHEN YOU CHOOSE US TO ASSIST YOU IN THIS PROJECT.

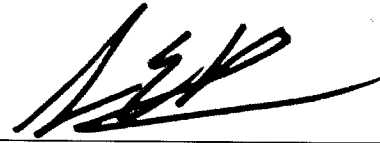

Spence Bledsoe, Project Manager

TEL:
 sbledsoe@preventronics.com

CUSTOMER SIGNATURE

DATE

PO NUMBER

AMOUNT

Proposals:

Preventronics

- 123 cameras
- \$153,729 total cost
- \$1,250/cost per camera
- \$15,372 Optional service/maintenance annual contract

Johnson Controls

- 84 cameras
- \$186,905 total cost
- \$2,213/cost per camera
- \$21,327 Annual service charge and license

Titan Alarm

- 103 cameras
- \$135,823 total cost
- \$1,319/cost per camera
- \$8736 Annual license fee

November 20, 2022—Intruder at Las Campanas, women’s locker room.

February 9, 2023—Apparent migrant bathing in sink at SRS in restroom near Photography Club-fled across the footbridge to a waiting vehicle.

March 1, 2023—Intoxicated person climbs wall at Desert Hills around midnight and struggles to remain awake in the spa. Is still on the premises at 5am.

There have also been reports of verbal and physical altercations between members, harassment, minor theft, and injuries from fitness equipment.